



---

# **Texas RE & ERCOT Generator Weatherization Workshop**

**September 7, 2016**

---

# Agenda

Description	Presenter
Introductory Remarks	Mark Henry, Texas RE <a href="mailto:mark.henry@texasre.org">mark.henry@texasre.org</a>
Lessons learned and best practices to improve reliability during extreme cold weather.	Panda Temple – William Petersen <a href="mailto:wpetersen@pandatempletx.com">wpetersen@pandatempletx.com</a>
Lessons learned and best practices to improve reliability during extreme cold weather.	NRGTX CBY4 – David Hunt <a href="mailto:David.Hunt@nrg.com">David.Hunt@nrg.com</a>
Break	
Lessons learned and best practices to protect instrumentation from freezing.	AMETEK O'Brien - John Kozich <a href="mailto:John.Kozich@ametek.com">John.Kozich@ametek.com</a>
Extreme cold weather and benefits seen from starting units early and other actions for red flag days.	Chad Thompson – Manager Operations Support, ERCOT <a href="mailto:cthompson@ercot.com">cthompson@ercot.com</a>
Break	
Lessons learned, best practices and observations from winter 2015-2016 spot checks.	Alan H. Allgower, ERCOT <a href="mailto:alan.allgower@ercot.com">alan.allgower@ercot.com</a>
Preliminary winter outlook 2016-2017.	Chris Coleman, ERCOT <a href="mailto:chris.coleman@ercot.com">chris.coleman@ercot.com</a>
Closing comments	Mark Henry, Texas RE

# Emergency Procedures

- In the case of an emergency, stairwells can be found on either side of the main suite entrance (restrooms, too).
  - Our muster point is in front of the building, by the guardrail past the temporary parking spaces
- AED defibrillation device located in the office.



# Antitrust Admonition

**Texas Reliability Entity, Inc. (Texas RE) strictly prohibits persons participating in Texas RE activities from using their participation as a forum for engaging in practices or communications that violate antitrust laws. Texas RE has approved antitrust guidelines available on its web site. If you believe that antitrust laws have been violated at a Texas RE meeting, or if you have any questions about the antitrust guidelines, please contact the Texas RE General Counsel.**

# Questions?



# Winter Weather Best Practices

Presented by Bill Petersen – Plant Engineer  
Panda Temple Power, LLC

# Presentation Topics

- \* Brief Facility Description
- \* New Facility Challenges
- \* Weatherization Procedure
- \* Protection Verification/Installation
- \* ERCOT Interaction
- \* Seasonal Review



**Panda**TemplePower

# Panda Temple Power

- \* Located in Temple, TX
- \* Plant consists of two Siemens Flex Plant Power Island 758MW packages utilizing:
  - \* Four Siemens SGT6-5000F(5) combustion turbines,
  - \* Two Siemens SST6-5000 condensing reheat steam turbines and
  - \* Four NEM Benson once-through HP evaporator HRSGs



# Panda Temple Power (cont.)

- \* Commercial Dates
  - \* Power Block I – July 2014
  - \* Power Block II – May 2015
- \* Winter Weather Design
  - \* Minimum Ambient Temperature of °15F
  - \* Wind – 15mph





PANDA TEMPUK  
@www.joegriffinphotography  
11/14/14

# New Facility Challenges

- \* Exposed Heat Trace Cables
- \* Loose Wire Connections
- \* Bad MI Cables
- \* Incomplete Insulation
- \* Open Circuits



# Winter Weather Procedure

- \* Safety Management Plan (SMP-2)
  - \* ICP-16 Seasonal Readiness
    - \* Winter Readiness Action Meeting
    - \* Work Scope and Checklist Completion
    - \* Management Verification
    - \* Attestation
    - \* Season Critique

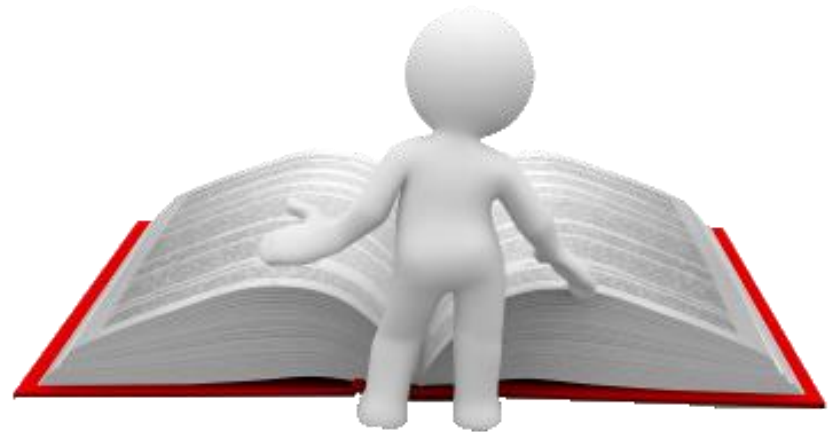

# Winter Weather Procedure (cont.)

- \* Key Parts of ICP-16
  - \* Personnel Training
  - \* Cold Weather Emergency Kit Inventory
  - \* Wind Wall Locations by Instrument
  - \* HVAC Inspections
  - \* Heat Trace and Insulation Verification
  - \* Critical Transmitter Identification
  - \* Extreme Cold Weather Checklists



# Winter Weather Procedure (cont.)

- \* Personnel Training
  - \* Topics covered include:
    - \* ERCOT lessons learned
    - \* Emergency weather equipment
    - \* Work Scope and Checklists of ICP-16
    - \* Extended Weather Outlook
    - \* Emergency Rounds during “Extreme Cold Conditions”

# Winter Weather Procedure (cont.)

- \* Cold Weather Emergency Kit Inventory
  - \* Extension Cords
  - \* Duct Tape
  - \* Heat Guns
  - \* Propane heaters
  - \* Tarps
  - \* Tie Wraps
  - \* Electric Heat Lamps



# Winter Weather Procedure (cont.)

- \* Temporary Wind Walls
  - \* Locations identified by maps and instrumentation
  - \* Scaffolding
  - \* Non-flammable
  - \* Durable
- \* Polypropylene Material



# Winter Weather Procedure (cont.)

- \* Additional Wind Protection
  - \* Recommended during ERCOT visit
  - \* Reduces vertical drafting on the HRSGs
  - \* Plywood or Fiberboard

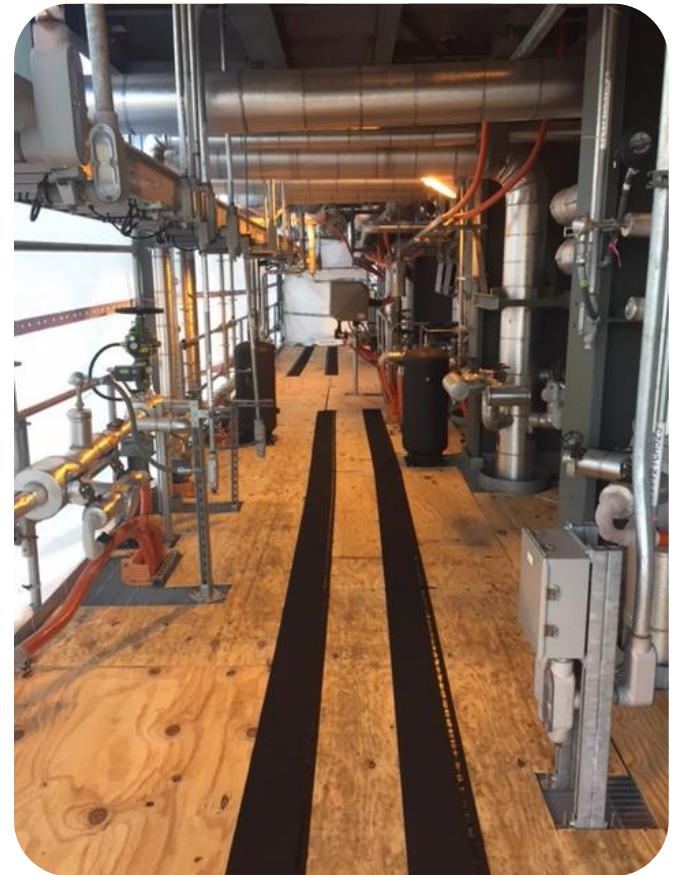

# Winter Weather Procedure (cont.)

- \* Critical Transmitters
  - \* Identified separately within the procedure
  - \* Description, Location, Type of Weather Protection

Appendix 11: Critical Transmitters

Device	Description	Transmitter Location	Heat Trace	Insulation	Windwalls
10MAG10CL021	CONDR 1 LVL	S.E. Corner of Condenser, Ground Level	X	X	X
10MAG10CL022	CONDR 1 LVL	S.E. Corner of Condenser, Ground Level	X	X	X
10MAG10CL023	CONDR 1 LVL	S.E. Corner of Condenser, Ground Level	X	X	X
11HAD30CL001	HRSG11 SEPARATOR LVL 1 HP	West side of HRSG, mid-level under separator	X	X	
11HAD30CL002	HRSG11 SEPARATOR LVL 2 HP	West side of HRSG, mid-level under separator	X	X	
11HAD30CL003	HRSG11 SEPARATOR LVL 3 HP	West side of HRSG, mid-level under separator	X	X	
11HAD50CL001	HRSG11 IP DRUM LVL 1	East side of HRSG, Top, Second Level From Top	X	X	
11HAD50CL002	HRSG11 IP DRUM LVL 2	West side of HRSG, Top, Third Level From Top	X	X	
11HAD50CL003	HRSG11 IP DRUM LVL 3	West side of HRSG, Top, Third Level From Top	X	X	
11HAD50CP001	HRSG11 IP DRUM PRES	East side of HRSG, Top, Second Level From Top	X	X	
11HAD80CL001	HRSG11 IP DRUM LVL 1	East side of HRSG, Top,	X	X	

# Winter Weather Procedure (cont.)

- \* Extreme cold weather checklist
  - \* Temperatures at or below 32 degrees
  - \* Pump/Skid Freeze protection checklist every four hours
  - \* Instrumentation box heater verification
  - \* Other items identified in checklist
- \* Additional staffing, pump/skid freeze protection checked hourly, and “screwdriver alerts” will be required when:
  - \* Outside temps are less than 20 degrees
  - \* Outside temps are less than 25 degrees with winds speeds greater than 20 mph
  - \* Temps are forecasted to be below freezing for more than 24 hours



# Protection Verification/Installation

- \* Annual Heat Trace Audits
  - \* Comprehensive
    - \* Schedule in September
  - \* Self Performed or Third Party
    - \* If Third Party used, IC&E technician oversees audit
  - \* Heat Trace Circuit Spreadsheets
    - \* Test Current
    - \* Identify Deficiencies
      - \* Prioritize
      - \* Handle repairs through CMMS
  - \* Heat Trace Plant Drawings



# Protection Verification/Installation (cont.)

- \* Insulation Inspections
  - \* Conducted by plant personnel
  - \* Repairs scheduled in CMMS

## Appendix 1: System readiness review (winter)

System: \_\_\_\_\_ Date: \_\_\_\_\_

Evaluator: \_\_\_\_\_

Systems evaluated shall be inspected for the following items at a minimum:

- proper installation and operation of heat tracing
- insulation and lagging integrity
- signs of wet insulation under lagging
- water leaking from system piping or lagging
- verify all instrument sensing lines are adequately covered with insulation and heat tracing
- determine if temporary or permanent wind breaks are required to protect critical equipment or instrumentation from north and west winds

Evaluators should consider the impacts to plant operation should the system be subject to cold weather related issues affecting system piping, mechanical equipment and critical instrumentation.

# ERCOT Interaction

- \* ERCOT Notifications
  - \* Winter Readiness Procedure Updates
  - \* Declaration of Weatherization Preparation/Readiness
- \* ERCOT Weatherization Spot Checks
  - \* Lessons Learned from ERCOT Fleet
  - \* Improvement Recommendations
- \* ERCOT Weatherization Workshops



# Seasonal Review

- \* Winter Season Critique
  - \* Conducted by Plant Management
  - \* On or Before May 1st
  - \* Procedural Improvements
    - \* Living Document
  - \* Review previous winter related events
  - \* ERCOT Best Practices



# Summary

- \* Weatherization Procedure
  - \* Living Document
  - \* Continually Improved
- \* Critical Instrument Identification
- \* Heat Trace Audits
  - \* Begin Sooner than Later
  - \* Good QA/QC of Heat Trace and Insulation
- \* Communication
  - \* Share incidents' Lessons Learned to prevent repeats

# Cedar Bayou Unit 4 Freeze Protection Review



# Cedar Bayou Unit 4 Combined Cycle Unit

---



- **Unit 41**
  - June 24, 2009
  - Gas Fired
  - Gross MW = 188
- **Unit 42**
  - June 24, 2009
  - Gas Fired
  - Gross MW = 188
- **Unit 4**
  - June 24, 2009
  - Gross MW = 171



**Unit 4**

**Unit 41**

**Unit 42**

---

# Outline

---



- **Physical Plant Improvements**
  - **Corporate Procedure**
  - **Plant Procedure**
-



**Typical condition prior to freeze protection upgrade**



# Evaluation of Physical Improvements Needed



- Contracted a third party engineering group to evaluate existing freeze protection system
  - Determine changes required to enhance system rating
    - As built: 22° and 25 MPH
    - New specification: 0° and 25 MPH
-

# Physical Improvements



- Install HRSG Steam Drum End Enclosures
  - Install Heated Transmitter Enclosures
  - Upgrade Heat Tracing and Insulation to 0° spec.
-



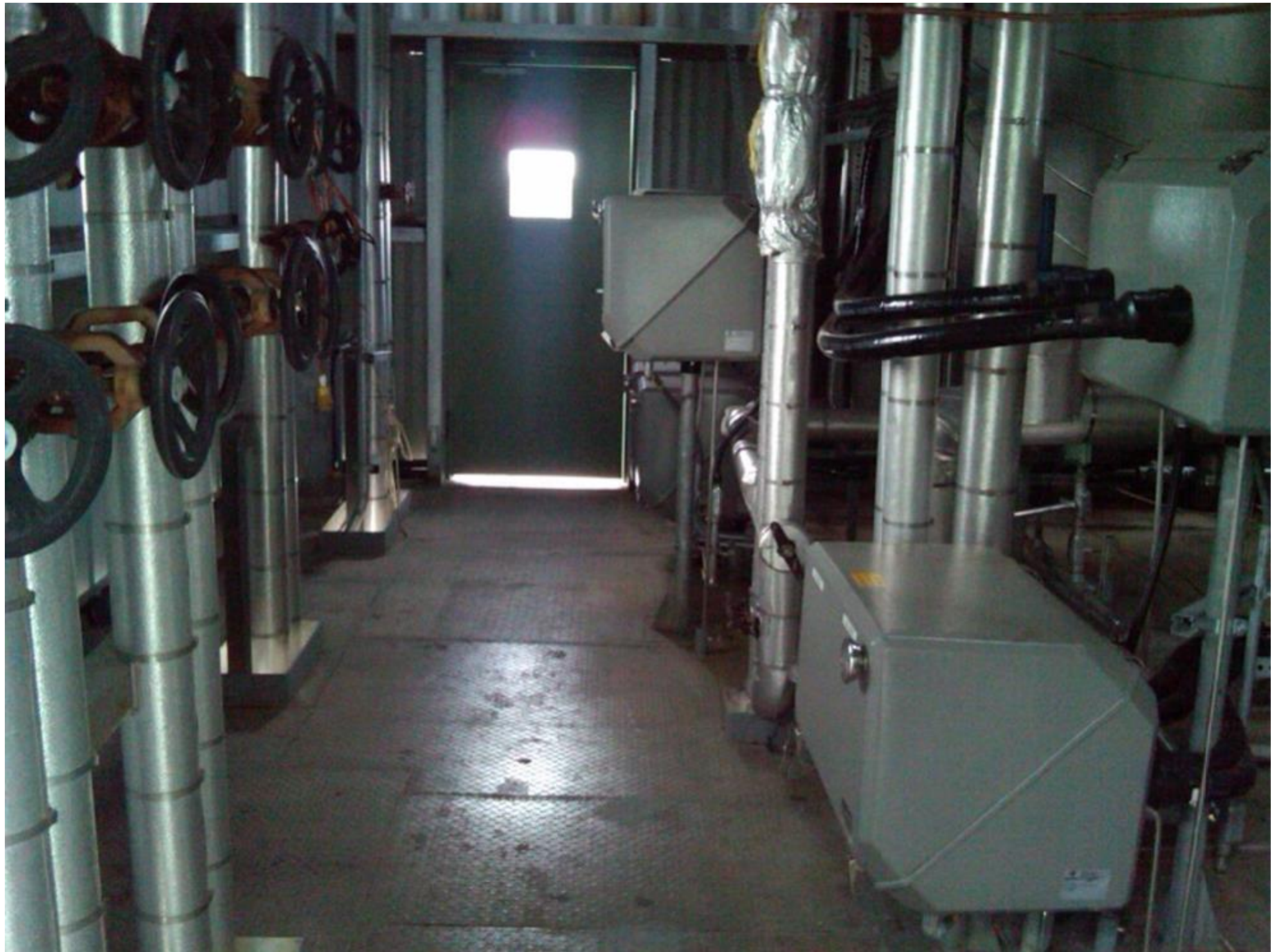





# Corporate Winter Readiness



- Monthly regional corporate winter readiness calls
- Annual plant review and update of winter readiness procedure
- Plants complete all readiness activities and certify winter readiness
- Daily regional calls with all impacted plants during freeze events
- Post season lessons learned review

# CBY Plant Winter Readiness Key Components



- Pre-Winter Checks
- Pre-Event Checks
- Event Checks
- Maintain Year Round
- Involve the Whole Team

# CBY Plant Winter Readiness Key Components



## Pre-Winter Checks

- All activities completed prior to November 1<sup>st</sup>
  - Summer Insulation Review
  - Heat Tracing
  - Cabinet Checks
  - Build Wind Breaks
  - Temporary Heater Placements
  - Supplies Purchased

**Windbreaks – Pre-Winter Installation**

Install windbreaks and inspect condition of permanent windbreaks and ensure they are in good condition prior to December 1<sup>st</sup>. All issues must be identified and repairs completed by December 1<sup>st</sup>.

Date / /

Checks performed by: \_\_\_\_\_

<b>Windbreaks to be Installed</b>			
<b>Unit 1</b>	<b>Location</b>	<b>Installed</b>	<b>Initials</b>
1	Convection Pass Pressure Trans Cab and Sensing Lines	7 <sup>th</sup> lvl - West side	
<b>Unit 2</b>			
1	Convection Pass Pressure Trans Cab and Sensing Lines	7 <sup>th</sup> lvl - east side	
2	2A BFPT oil coolers and piping	East end of power block area	
<b>Unit 4</b>			
1	Steam Turb and Vac Pump area	East of Condenser and Vac Pmp	
2	CT 41 BFP area	North side of BFP	
3	CT 42 BFP area	North side of BFP	
4	CT 41 – HRH/CRH control boxes	Dance Floor	
5	CT 42 – HRH/CRH control boxes	Dance Floor	
<b>Yard</b>			
1	Ammonia injection pumps (U1 & U2)	East of Unit 3	
2	Ammonia injection pumps (U4)	East of Unit 3	
3	Ammonia tank sight glasses	East of Unit 3	
4	CWT diverting valve area	West end of CWT basin	
5	BCP diverting valve area	South end of BCP basin	
6	Make-up Caustic pump area	Make-up – west of building	
7	A Intake bleach valves	A intake – east end	
8	U4 bleach pumps	U4 Intake	
9	U4 Main Gas trip valve area	East of Misc building	
10	U4 ACT Bleach and RI Systems	West of U4 ACT	
11	Potable Water System	North of Make-up	

<b>Permanent Windbreaks</b>			
<b>Unit 1</b>	<b>Location</b>	<b>Condition / Initials</b>	
1	1A & 1B Vaporizer Skids	3 <sup>rd</sup> lvl – East and West sides	
<b>Unit 2</b>			
2	2A & 2B Vaporizer Skids	3 <sup>rd</sup> lvl – West side 4 1/2 lvl – East side	
<b>Yard</b>			
3	Make-up Demin Ammonia pump area	Make-up area	
4	Potable Water System	North of Make-up	
5	CECP Chemical pump area	West of BCP basin	



# CBY Plant Winter Readiness

## Key Components



## Pre-Event Checks

- Items to be completed prior to temperature reaching 35°F
  - Place heat tracing in service
  - Verify using checklists
    - Heat tracing
    - Windbreaks
    - Heaters
  - Establish staffing plan
    - 24 Hr. supplemental coverage
    - Send personnel home, if needed

# CBY Plant Winter Readiness

## Key Components



## Event Checks

- Tasks completed during an winter weather event
- Frequency of monitoring based on outside temperature and expected duration of event.
  - 40°F – Make initial rounds
  - $<40^{\circ}\text{F} \geq 34^{\circ}\text{F}$  – Critical and All Items every 12 hours
  - $<34^{\circ}\text{F} \geq 28^{\circ}\text{F}$  – Critical every 4 hours, All Items every 8 hours
  - $<28^{\circ}\text{F}$  – Critical every 2 hours, All Items every 4 hours

# CBY Plant Winter Readiness

## Key Components



### – “All Item” vs Critical Items

- Critical Items

- Greatest impact on unit
- Highest elevation or exposure
- Bold on all checklist
- Below freezing, inspection frequency doubled

- “All Items” – Everything else

- Instrument air low point drains
- Ground level freeze protection cabinet
- Windbreaks and heaters

APPENDIX 6 – EVENT CHECKS  
**Freeze Protection Checks – All Items (Critical and Non-Critical)**  
*Critical in bold & italic*  
**UNIT – 4**



This form is to be used for making the All Items rounds (Critical and Non-Critical). See “Winter Event Interval Guidelines” for frequency of rounds.

Date: \_\_\_\_\_ Time: \_\_\_\_\_ Outside Temp: \_\_\_\_\_  
 Name: \_\_\_\_\_

DANCE FLOOR LEVEL		Location	Temp	Comments/Initials
	SRH PRESS, PT – 42 – 166 – 01	INLET OF 42 HP BYPASS VALVE ON DANCE FLOOR		
	SRH PRESS, PT – 42 – 106 – 02	INLET OF 42 HP BYPASS VALVE ON DANCE FLOOR		
	SRH PRESS, SRH – PT04212 – 01	NORTH EAST DANCE FLOOR AT RH LINE		
	SLP PRESS, PT – 41101-01	EAST OF HRSG, NORTH SIDE OF LP FW HTR		

Instrument Air Blow Down		Drained (Y/N)	Moisture Present (Y/N)	Comments/Initials
Ground	SE corner of dance floor			
	4b vacuum pump			
	4a vacuum pump			
	East condenser North side (HRH drain)			
	Hotwell emergency dump to 41 HRSG sump			
	Top edge of pit N of 41 bldn tank			
	Air to 41 HRSG, S of LP stm outlet pipe			
	Air to 42 HRSG, S of LP stm outlet pipe			
	SE of 42 HRSG sump pumps			
	West of N end of 42 perf htr			
	CT42 isophase duct control panel			
	CT41 isophase duct control panel			
	ST04 isophase duct control panel			

Ground Level Freeze Circuit Checks		Verify no fault or alarm lights lit on cabinet. Any Fault lights lit? (Y/N)	Immediately report any fault lights lit. Comments/Initials
Level	Location		
	South of Misc. Building		
	South of 41 HRSG load center		
	South of 42 HRSG load center		
	West of 41 Performance heater		

U4 Instrument Air Dew Point		Dew Point	Comments/Initials
Base	Dew Point reading		

## Supervisor Shift Checklist

(To be completed by SS or IC each shift while in a Freeze event (Alert Level 2 or Severe Winter Weather Alert))

Shift: **DAYS NIGHTS** Date: \_\_\_\_\_ Time: \_\_\_\_\_ Temp: \_\_\_\_\_

Alert Level (2, or Severe Winter Weather Alert) at start of watch: \_\_\_\_\_

Plant Freeze Coordinator (Shift Super or Incident Commander): \_\_\_\_\_

	Yes	No	Initial
Staff levels adequate for existing and potential conditions?			
Tailgate meeting held with all plant personnel to discuss; <ul style="list-style-type: none"> <li>• Safety - (Ice Accumulation on walking surfaces, falling ice, Icing on roadways (vehicular travel restrictions), skin exposure risk)</li> <li>• Environmental Considerations</li> </ul>	Yes	No	
Emergency Materials Staged?	Yes	No	
Freeze Protection Circuits on?	Yes	No	
Pre Event Checks Completed?	Yes	No	
Winter Event 'Check Intervals Guidelines' reviewed and Monitoring established?			
<ul style="list-style-type: none"> <li>• 'All Items and Critical Items' Rounds</li> </ul>	Yes	No	
<ul style="list-style-type: none"> <li>• Dew points</li> </ul>	Yes	No	
<ul style="list-style-type: none"> <li>• Check Windbreaks (once per shift)</li> </ul>	Yes	No	
<ul style="list-style-type: none"> <li>• Check Temporary Heaters (once per shift)</li> </ul>	Yes	No	

### Shift Turnover

Time of last Critical Cabinet round: \_\_\_\_\_ Next Round due at: \_\_\_\_\_

Time of last Non-Critical Cabinet round: \_\_\_\_\_ Next Round due at: \_\_\_\_\_

'A' Side Diesel storage tank level: \_\_\_\_\_ Unit 4 Emergency Generator fuel level: \_\_\_\_\_

Time of last Diesel Gen test (U1): \_\_\_\_\_ (U2): \_\_\_\_\_ U4 Emerg. Diesel: \_\_\_\_\_

Inst Air Dew Point (U1): \_\_\_\_\_ (U2): \_\_\_\_\_ (U4): \_\_\_\_\_

All checklists collected (Shift, All Items, Critical Items)? **YES NO** \_\_\_\_\_



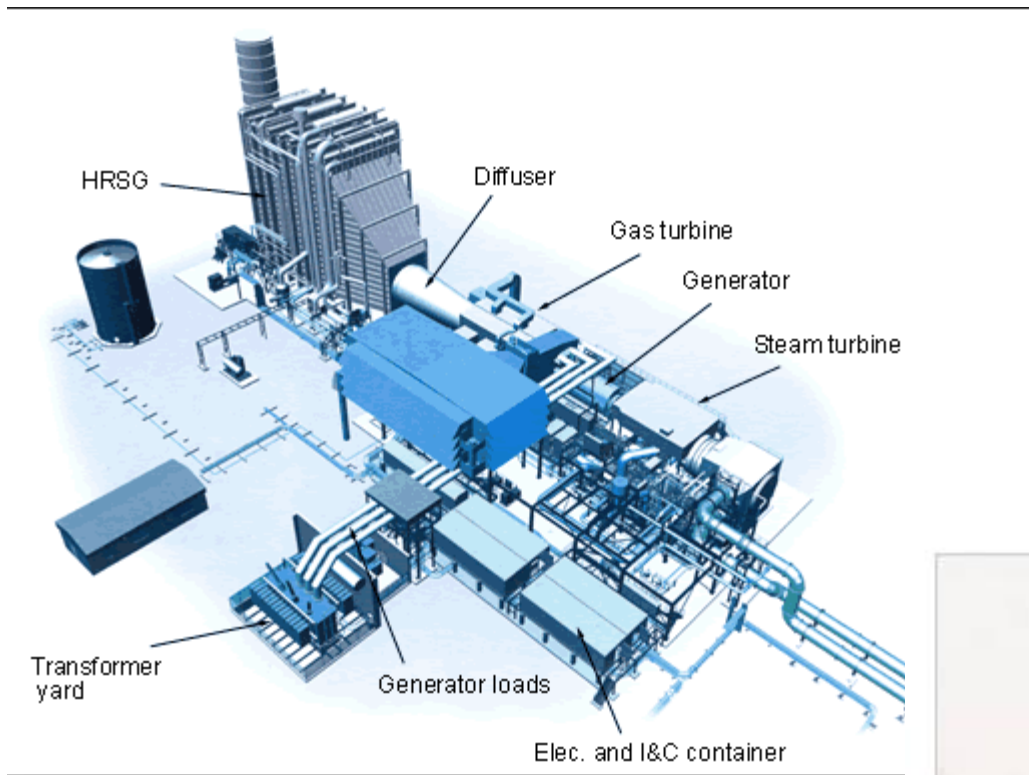

# ERCOT

## Instrumentation Freeze Protection



## Instrument Protection

- Instrument winterizing is currently a combination of independent products, designs and crafts often with little incentive to work together.
- Miscommunications surrounding loop completion (engineering, design, procurement, receiving, construction) are the root cause of expensive change orders, wasted man hours and materials on any project.

## Relevant Terms:

- Instrument:
  - Pressure transmitter - FT, PT, LT, PDT
  - Impulse line
  - DP cell
- Blowdown – periodic flushing of the impulse line.
- Hazardous Area – electrically classified area, example: FM, Class I, Div 2.
- Root Valve – isolation valve on the process side of the impulse line.
- Blowdown valve – valve located near the instrument to initiate blowdown.
- Manifold – A device that regulates flow paths.
- Heat Tracing: electric or steam process heating.
- Instrument Heater: Independent heater installed within the instrument enclosure.
- Maintain temperature: Minimum acceptable process temperature. Corresponds to the temperature set point.

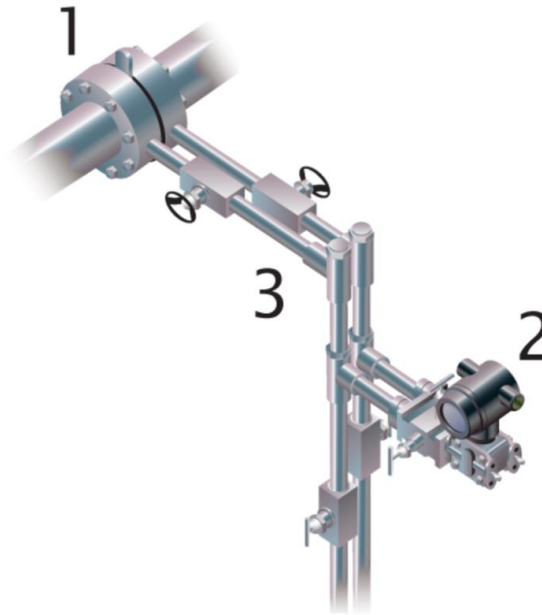

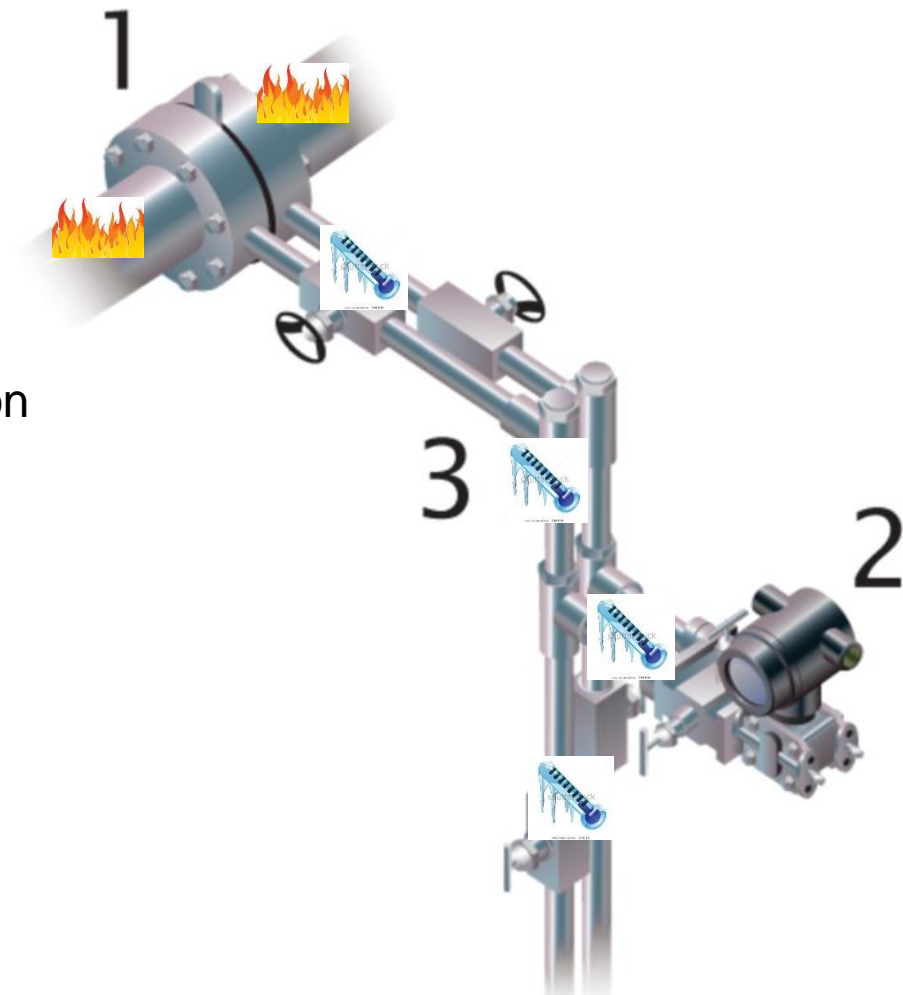

Normal Operation

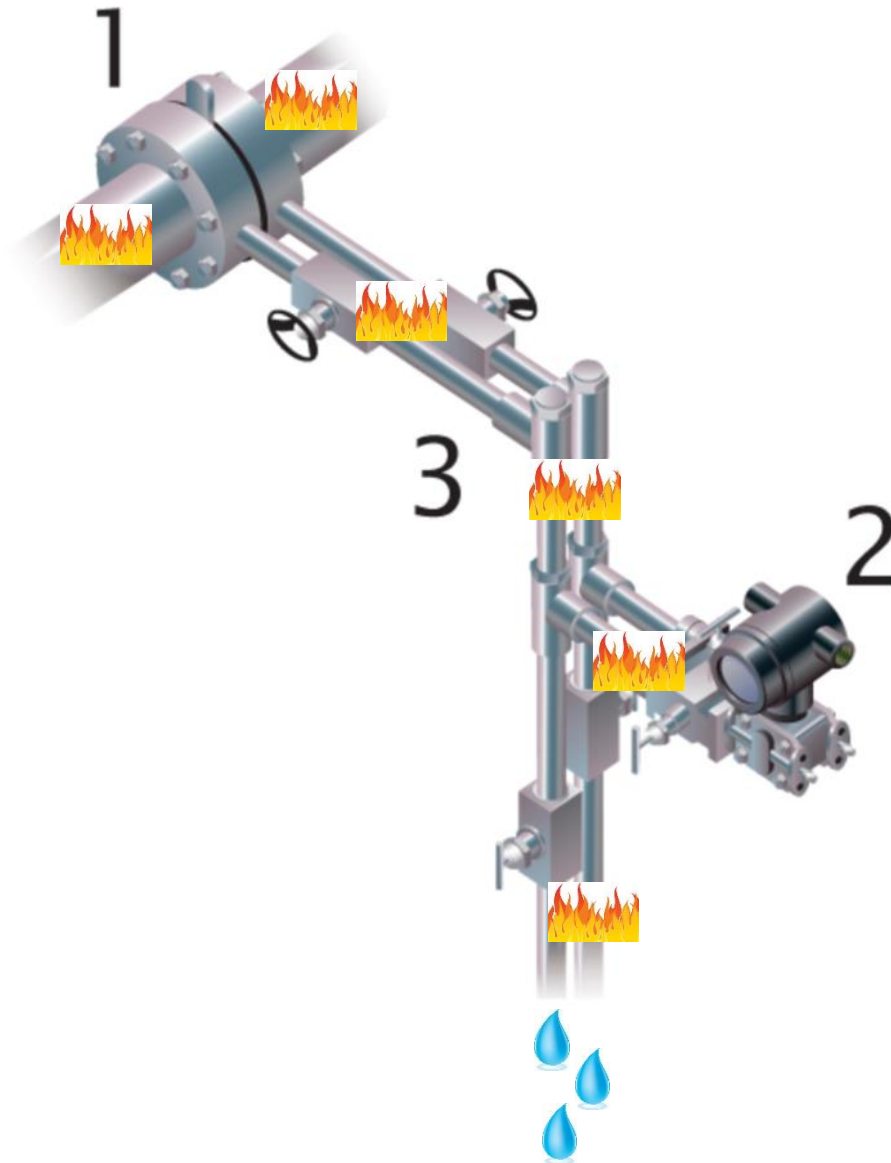

Blowdown



## Importance of Freeze Protection for Pressure Transmitter Loops

- Freeze protection is not a luxury. It is a must anywhere that has the potential to reach freezing temperatures – even for a short time.
- The instrument impulse loop is a non-flowing system. The fluid temperature will reach outdoor ambient temperature without external heating. Insulation alone will not protect from freezing.
- The optimal opportunity (best practice) for freeze protection is during initial installation.
- Post-installation freeze protection is possible.

## Environmental Chamber Test Results

<b>Tube Type</b>	<b>Insulation</b>	<b>Time to Reach 32°F (min)</b>	<b>Additional Time to Completely Freeze (min)</b>
3/8" X .035" Copper	No	5	22
1/2" X .035" 316 SS	No	7	35
3/8" X .035" Copper	Yes	14	166
1/2" X .035" 316 SS	Yes	19	251

## Installation Examples: The forgotten instrument



Some instruments are simply over-looked but should be protected

## Unsealed Openings

CUT-OUTS TOO LARGE



Openings allow cold air to enter and heat to escape

NOT EVEN CLOSE

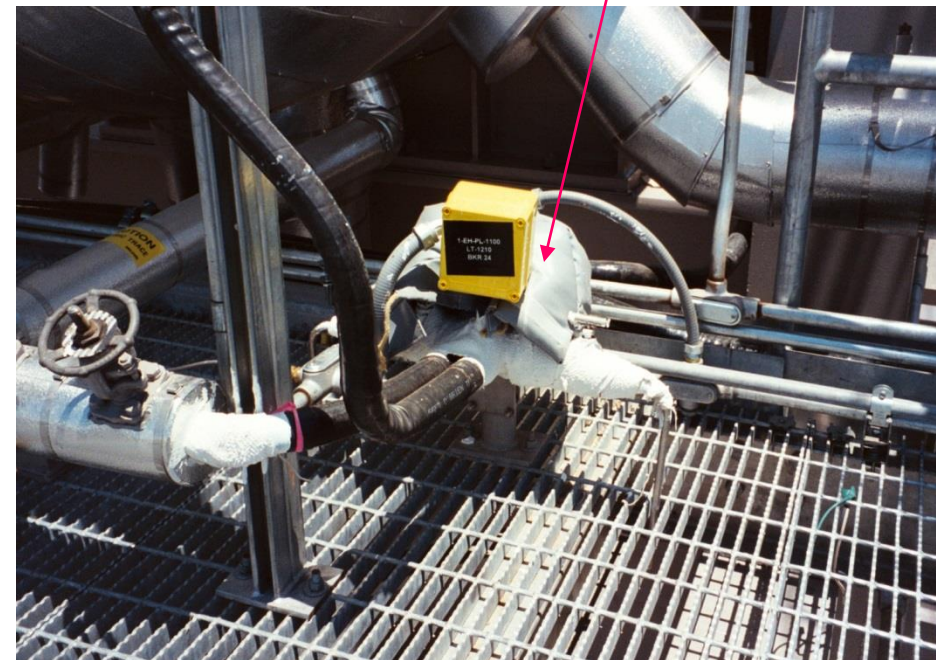

Often Flexible enclosures are never installed correctly.

## Exposed Blow Down Valves



Requires additional heating and insulation as they are not protected by the enclosure



## Uninsulated or Untraced Connections

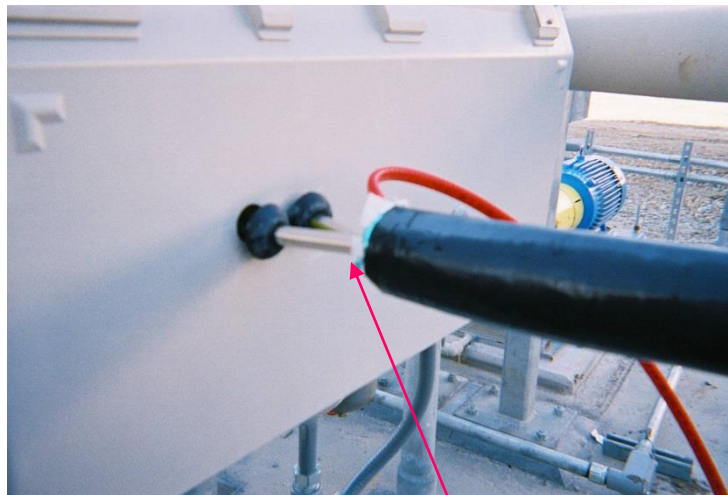

EXPOSED INSULATION



**Bundle must be run all the way into enclosures. 1" of exposed tubing will freeze up without heat or insulation.**

## Un-insulated or untraced Connections



Front



Back

Connections should be made **INSIDE** the enclosure.

## Design Considerations and Best Practices

- The line design temperature should be considered. HP drums can operate at temperatures in excess of 1100°F. This can have impact on the enclosure design.
- Blowdown procedure to consider instrument overheating. Example: 15 or 30 second max duration.
- Blowdown valves within an enclosure.
- Ambient sensing thermostat is recommended for energy savings.
- Field tracing is craft sensitive, and often inadequate.
- Cable wrapped instrument is not recommended.
  - Insufficient wattage
  - Inconsistent installation/craft sensitive
  - Possible boil and instrument over-heating

## Design Considerations and Best Practices (continued)

- Refer to NERC guidelines
- Perform full evaluation of the heat tracing prior to the winter.
  - Check power supply
  - Temperature control / thermostat
  - Circuit breakers
  - Connections
  - Cabling
  - Current draw

**NERC**

NORTH AMERICAN ELECTRIC  
RELIABILITY CORPORATION

### **Lesson Learned**

**Plant Instrument and Sensing Equipment Freezing Due to Heat Trace and Insulation Failures**

# Freeze Protection Solutions

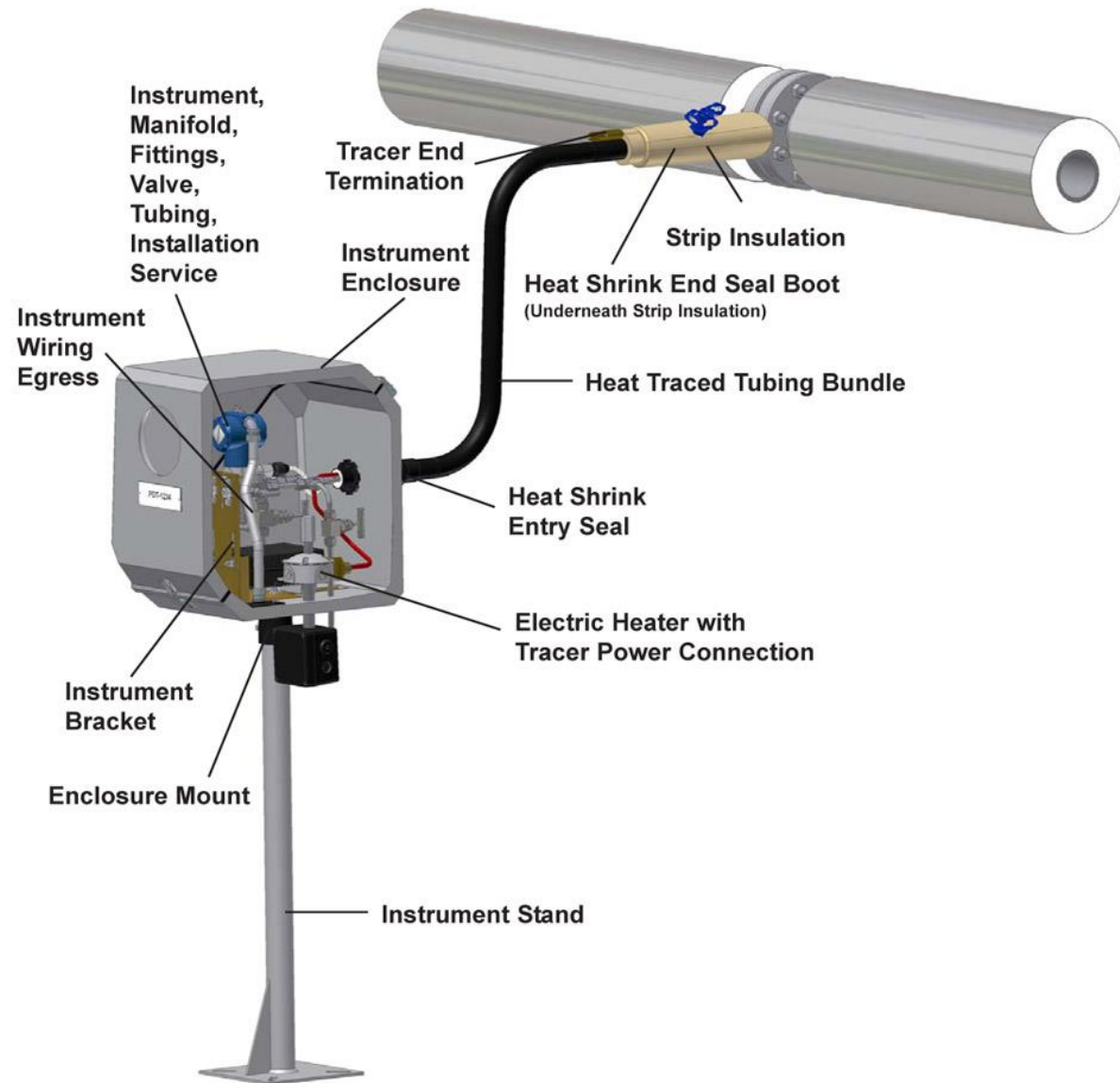

## Instrument Heating Basics

- Steam and electric heating options.
- Heating components to match area classifications (ex: FM Class I, Division 2).
- Convection and conduction heaters.
- Option for single power source for entire impulse loop.

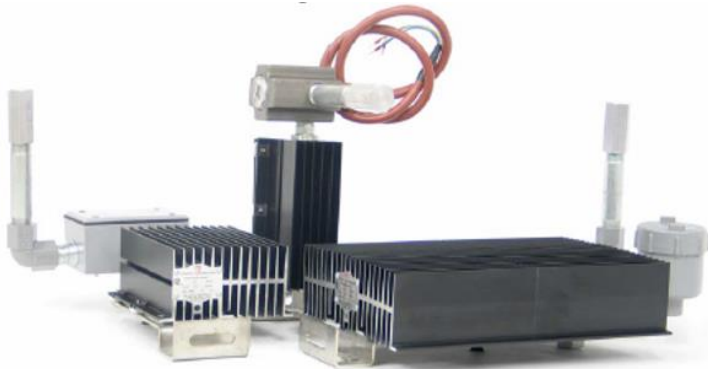

# Power Connection

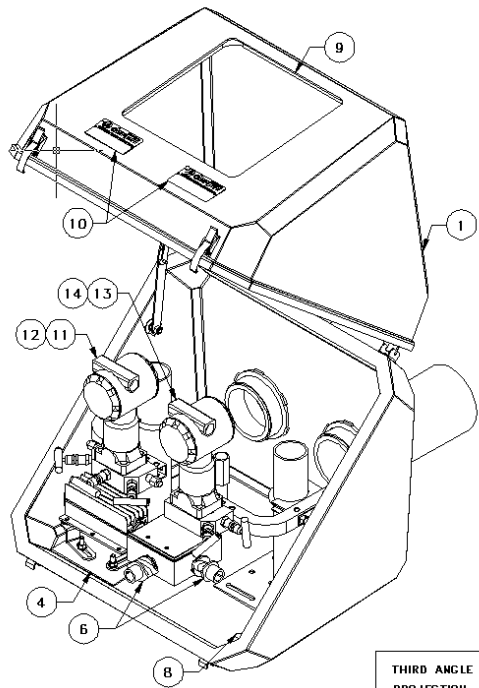

Internal

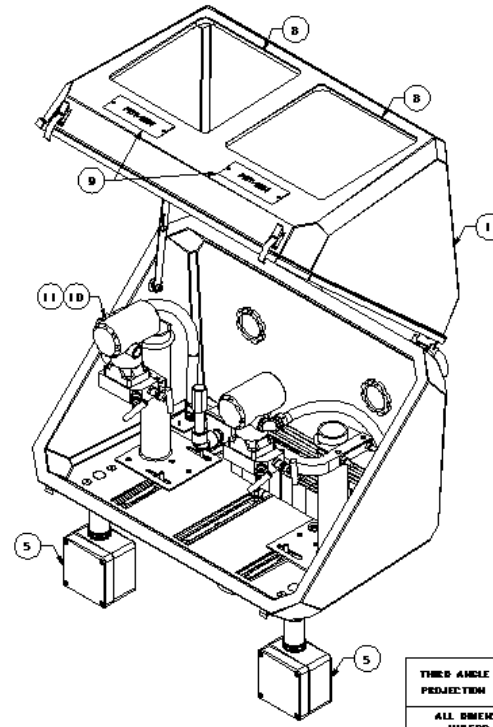

External

## Rear Process Entry

### A Series

#### *Accessible from every angle*

- Ideal for pressure, differential pressure and case type instruments in combination with manifolds, air sets, and purge meters.
- Top-hinged for easy access to process instruments from the front, top, or either side.
- Available in three sizes.
- Standard lid-support bracket keeps the lid open.
- Common options include:
  - mounting kits, heaters and factory-installed tempered glass windows.



## Top or Rear Process Entry

### B Series

#### *Front-door access*

- Ideal for case type recorders, indicators, controllers and sample handling or conditioning systems.
- Front door allows easy access to equipment.
- Available in 22 different sizes.
- Common options include:
  - mounting kits, rear access panels, surface plates, heaters and factory-installed tempered glass windows.



## Front Entry

### C Series

#### *Maximum access*

- Ideal for pressure, differential pressure and other transmitters in combination with manifolds, air sets, purge meters and output gages.
- Easy-open, tilt-back lid allows access from all sides.
- Available in 25 different sizes.
- Common options include:
  - lift access package, parting plates, mounting kits, heater and (W3) windows.



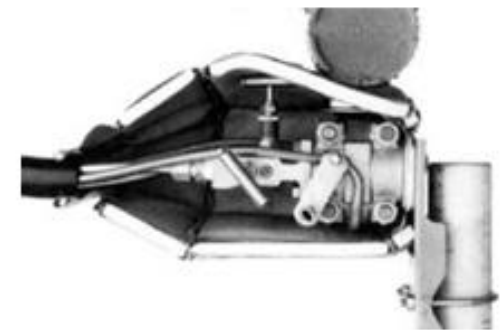

## Turn Key Solutions (factory installation of equipment)



Questions?



## **Planning for Cold Weather Events**

Chad Thompson  
Manager, Operations Support  
ERCOT, Inc.

Generator Weatherization Workshop  
September 7, 2016

# Outline

- Review Cold Weather Events
- Discuss Lessons Learned
- Discuss ERCOT's Initiatives

# Review: February 2, 2011, Cold Weather Event

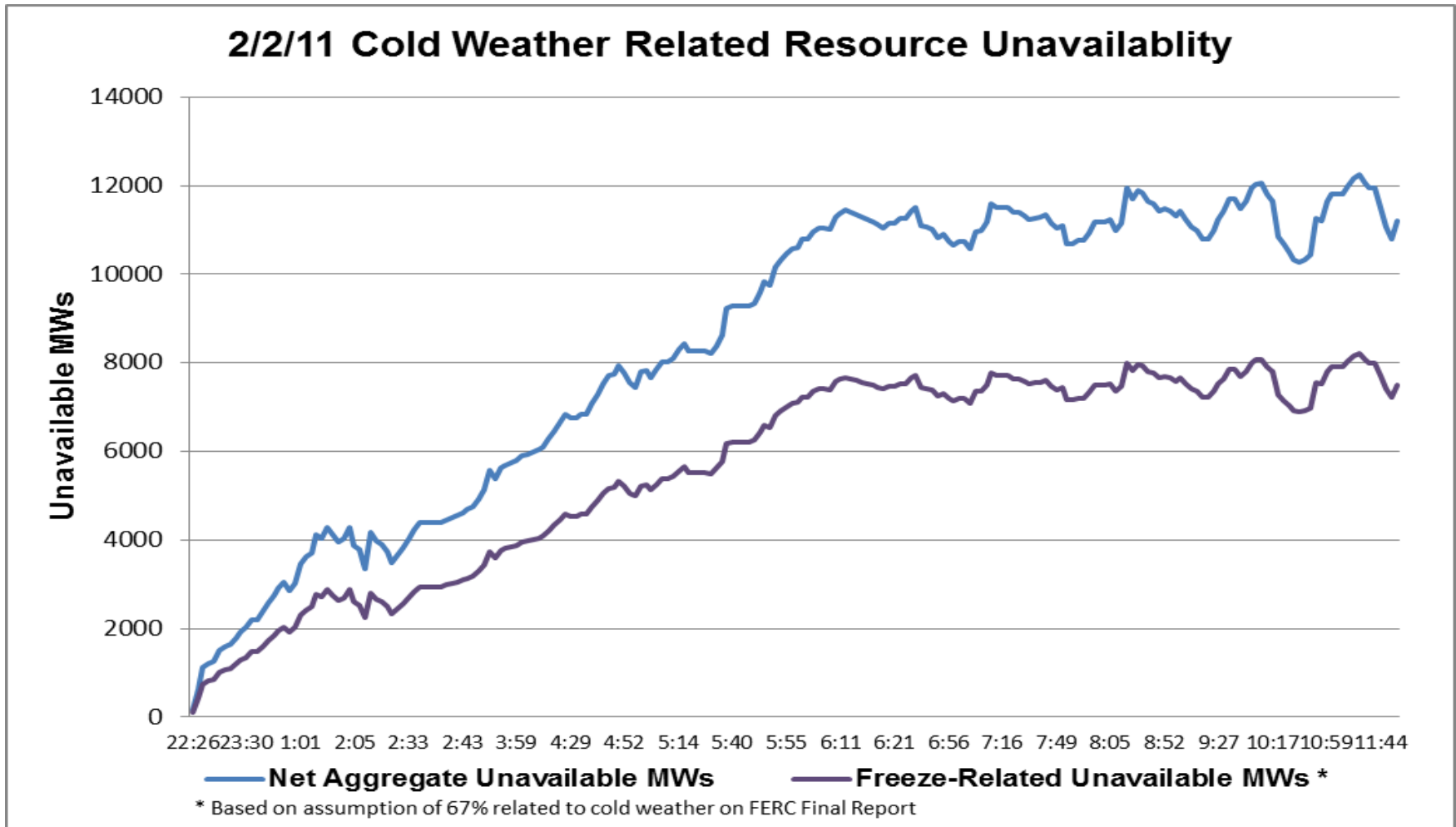

# Review: January 6, 2014, Cold Weather Event

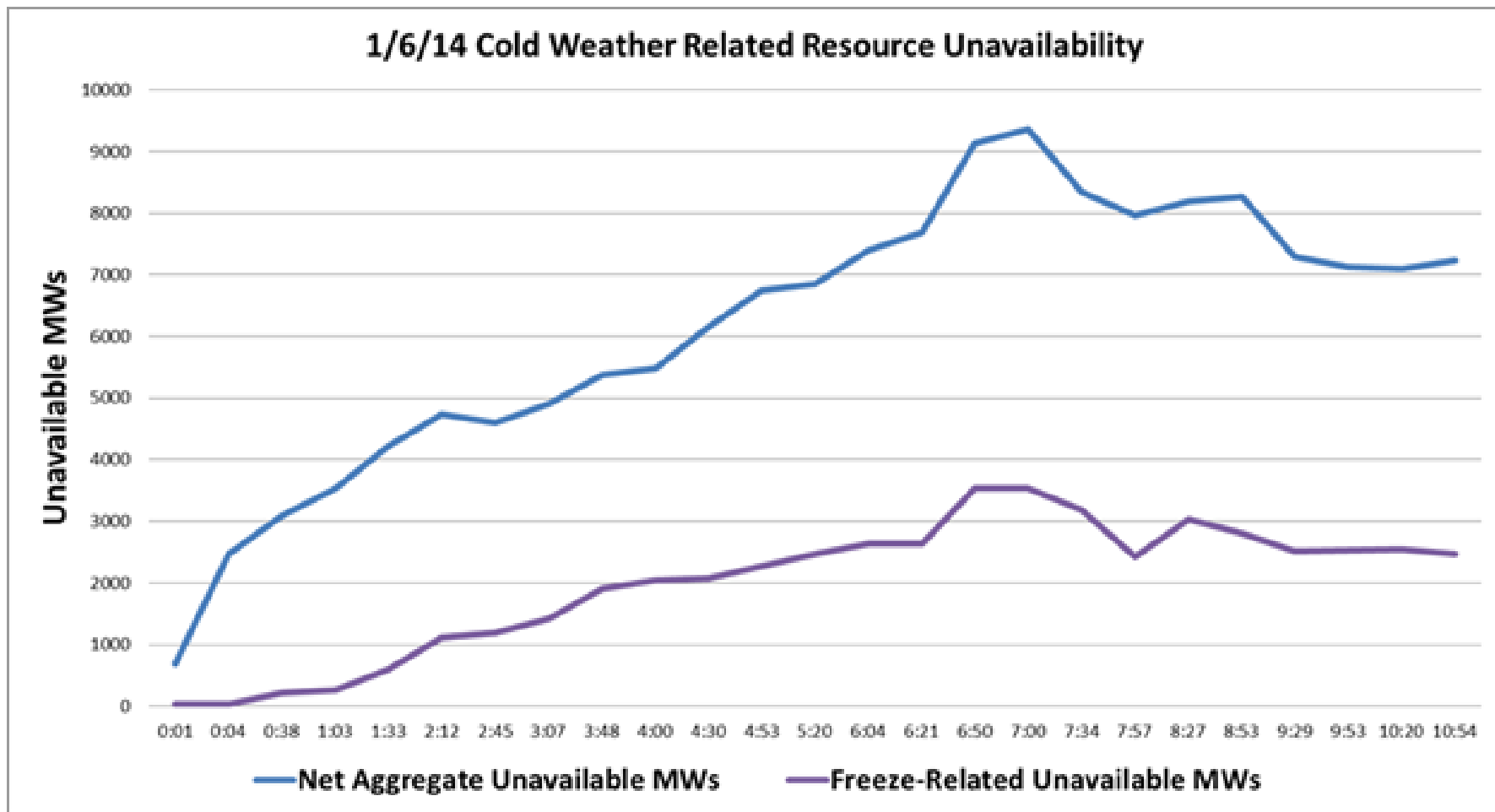

# Review: Comparison

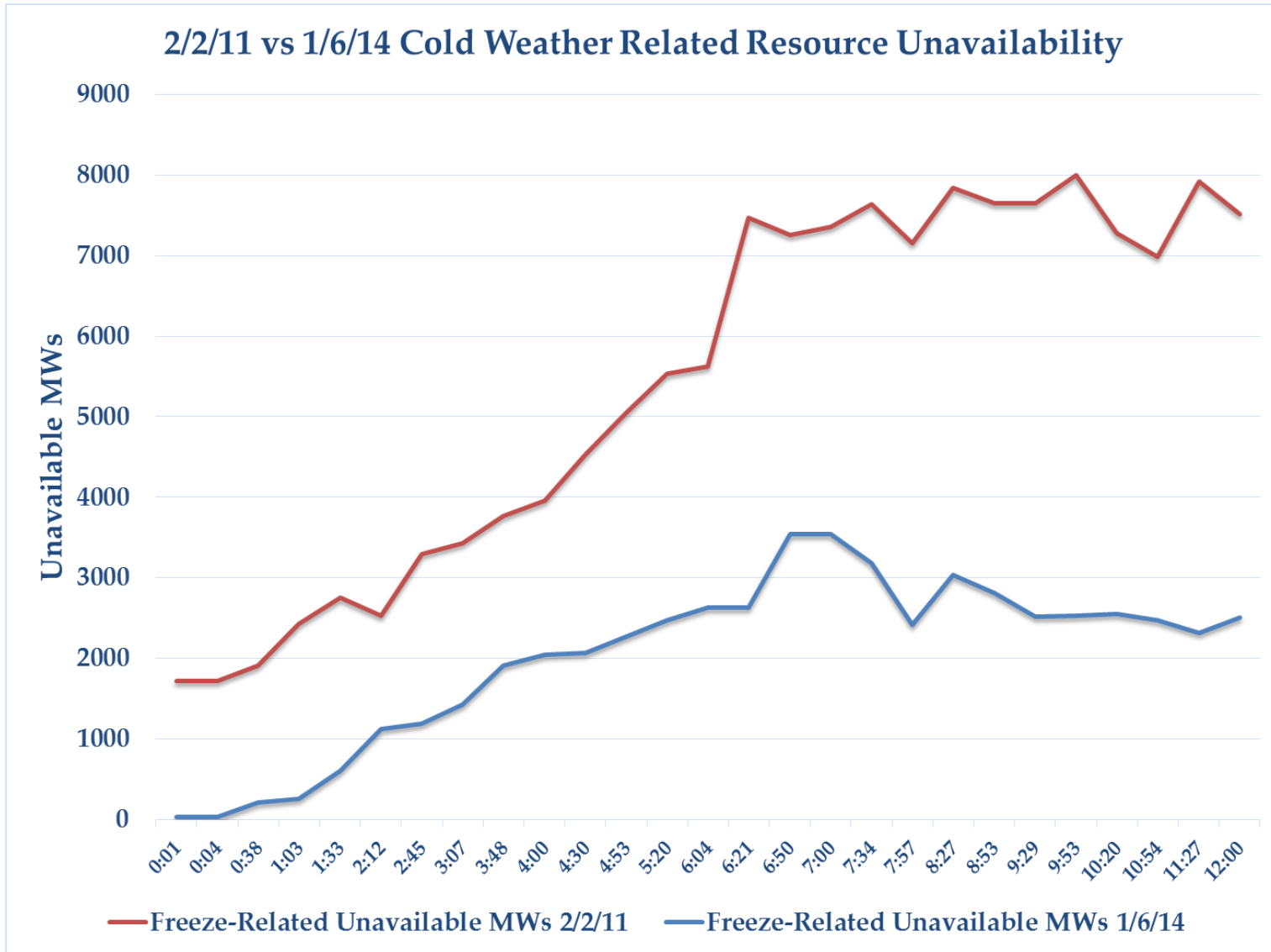

## Lessons Learned

- Cold weather preparations (e.g., heat tracing) have improved generator performance
- Still room for improvement
- Continue winterization site visits
- Performance improves after “the first event”

# Lessons Learned

- Observations
  - Texas plants are not insulated from weather compared to other regions
  - Cold units are harder to start and keep stable during cold snaps
  - Pre-Warming and/or early commitments can increase resistance to tripping

- “Red Flag” Meetings

- Who

- Outage Coordination
- System Operations
- Operations Support
- Meteorologist / Load Forecasting
- Market Operations

- What

- Updates on weather assumptions
- Cancel/Delay Planned Outages
- Commit generation on alternate fuel
- Commit generation with long lead times

- Increase Ancillary Service Requirements when cold weather is expected
  - When temperature is forecasted below 32°F and predicted HASL-Gen is below 600 MW
  - When temperature is forecasted below 20°F and predicted HASL-Gen is below 1300 MW



# **Generator Weatherization Workshop**

September 7, 2016

Alan H. Allgower  
Operations Analyst, Senior

[alan.allgower@ercot.com](mailto:alan.allgower@ercot.com)

512-348-4613 (o)

# What does a spot check entail?

- Objective is to build a working relationship with generator operators so that they are comfortable sharing information.
- Lessons learned from previous winters, observations, best practices and NERC lessons learned are all shared at each site.
- Generators are spot checked that they are following their weatherization plan.
- The spot check is NOT a comprehensive review of all plant equipment.
- ***ERCOT does not certify a generator is prepared for winter operations.***
- Every plant is left with recommended best practices, lessons learned, and PUCT requirements.

# Comparing February 2, 2011 to January 6, 2014

8000 MW of capacity tripped, failed to start or derated that was freeze related.

3541 MW of capacity tripped that was freeze related.

ERCOT declared EEA3 – 4000 MW firm load shed

## February 2, 2011

**Dallas:** 13° (20 MPH wind)  
**Houston:** 21° (16 MPH wind)  
**San Antonio:** 19° (25 MPH wind)  
**Austin:** 18° (26 MPH wind)  
**Brownsville:** 32° (26 MPH wind)  
**Abilene:** 7° (16 MPH wind)  
**Midland:** 6° (16 MPH wind)

ERCOT declared EEA2

## January 6, 2014

**Dallas:** 15° (9 MPH wind)  
**Houston:** 27° (16 MPH wind)  
**San Antonio:** 27° (15 MPH wind)  
**Austin:** 20° (13 MPH wind)  
**Brownsville:** 37° (17 MPH wind)  
**Abilene:** 11° (5 MPH wind)  
**Midland:** 14° (12 MPH wind)

Weather Source: Chris Coleman, ERCOT

# Comparing January 6, 2014 to January 8, 2015

3541 MW of capacity tripped that was freeze related.

750 MW of capacity tripped that was freeze related.

ERCOT declared EEA2

## January 6, 2014

**Dallas:** 15° (9 MPH wind)  
**Houston:** 27° (16 MPH wind)  
**San Antonio:** 27° (15 MPH wind)  
**Austin:** 20° (13 MPH wind)  
**Brownsville:** 37° (17 MPH wind)  
**Abilene:** 11° (5 MPH wind)  
**Midland:** 14° (12 MPH wind)

Normal Operations in ERCOT

## January 8, 2015

**Dallas:** 16° (5 MPH wind)  
**Houston:** 28° (6 MPH wind)  
**San Antonio:** 28° (8 MPH wind)  
**Austin:** 21° (7 MPH wind)  
**Brownsville:** 39° (16 MPH wind)  
**Abilene:** 16° (8 MPH wind)  
**Midland:** 20° (7 MPH wind)

Weather Source: Chris Coleman, ERCOT

# Spot Check 2015-2016 by Generation Type

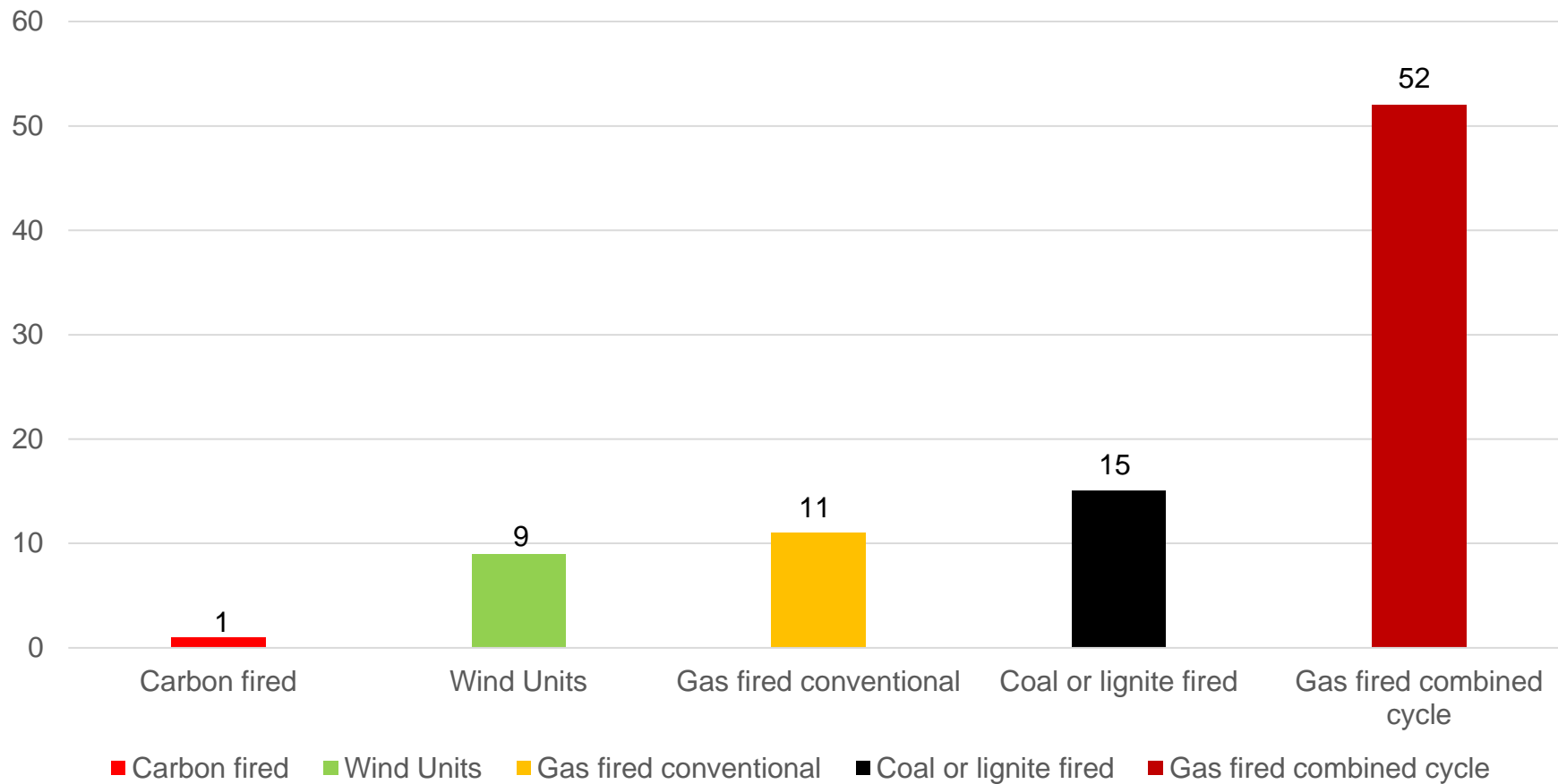

## Critical Components or Equipment

- §25.53. Electric Service Emergency Operations Plans.
  - (c)(2)(B) A plan that addresses any **known critical failure points**, including any effects of weather design limits.
- Nodal Protocol 3.20 (3)
  - ✓ No earlier than November 1 and no later than December 1 of each year, each Resource Entity shall submit the declaration Section 22, Attachment K, Declaration of Completion of Generation Resource Weatherization Preparations, to ERCOT stating that, at the time of submission, each Generation Resource under the Resource Entity's control has completed or will complete all weather preparations required by the weatherization plan for **equipment critical to the reliable operation** of the Generation Resource during the winter time period (December through February).
  - ✓ If the **work on the equipment that is critical to the reliable operation** of the Generation Resource is not complete at the time of filing the declaration, the Resource Entity shall provide a list and schedule of remaining work to be completed.
- Section 22, Attachment K, Declaration of Completion of Generation Resource Weatherization Preparations
  - ✓ "I hereby attest that all **weatherization preparations for equipment critical to the reliable operation** of each of the above-listed Generation Resources during the time period stated above are complete or will be completed, as required by the weatherization plan applicable to each Generation Resource."

## Critical Components Information from 2015/2016 Spot Checks

- In conducting 2015/2016 spot checks on generator weatherization plans, ERCOT visited **six units that listed critical components** that could trip or derate the unit if frozen.
  - These units **identified** associated heat trace circuits, insulation inspection and (and/or wind breaks and/or heaters, if required).
- In conducting 2015/2016 spot checks on generator weatherization plans, ERCOT visited **11 units that listed critical components** that could trip or derate the unit if frozen.
  - These units **did not identify** specific heat trace circuits, insulation inspection and (and/or wind breaks and/or heaters are not identified, if installed)
- In conducting 2015/2016 spot checks on generator weatherization plans, ERCOT visited **62 units that do not identify critical components** in their plan that could trip or derate their unit if frozen.

# Sample Template for Critical Components

Component description	Critical component	Reference heat trace circuit (cross reference to heat trace testing to ensure circuit is functioning )	Insulation inspection on sensing line (signature)	Transmitter cabinet inspection, are the heater and thermometer functioning? (signature)	Wind break installation (if required)	Additional heater (if required)
HP "A" drum level transmitter and sensing line	Yes	Heat trace panel 1 breaker 7			Yes	Yes
HP "B" drum level transmitter and sensing line	Yes	Heat trace panel 1 breaker 8			Yes	Yes
HP "C" drum level transmitter and sensing line	Yes	Heat trace panel 1 breaker 9			Yes	Yes
LP "A" drum level transmitter and sensing line	Yes	Heat trace panel 1 breaker 1			Yes	Yes
LP "B" drum level transmitter and sensing line	Yes	Heat trace panel 1 breaker 2			Yes	Yes
LP "C" drum level transmitter and sensing line	Yes	Heat trace panel 1 breaker 3			Yes	Yes
Boiler feed pump "1A" flow transmitter	Yes	Heat trace panel 1 breaker 10			No	No

# Heat Trace Testing from 2015/2016 Spot Check

- Six units provided records of heat trace testing.
  - ✓ *Identified the critical components associated with applicable heat trace circuit.*
- Sixty-two units provided records of heat trace testing.
  - ✓ *Did not identify the critical components associated with applicable heat trace circuit.*
- Eleven units could not provide records of heat trace testing.
  - ✓ *Recommended personnel to revise their plan requiring testing and develop spreadsheet comparing testing to design criteria, if known.*
  - ✓ *Recommended personnel to **identify the critical components** associated with applicable heat trace circuit.*

# Sample spreadsheet for heat trace testing

Panel 2HT-1 Circuit breaker	Circuit description	Critical component	Reference drawing number	Heat trace type	Design amperage	2013/2014 winter readings	2014/2015 winter readings	2015/2016 winter readings
1	LP "A" drum level transmitter	Yes	XXX-XXX-XXX	Series constant wattage	10A	9.5A	9.7A	5.0A
2	LP "B" drum level transmitter	Yes	XXX-XXX-XXX	Series constant wattage	7A	7.1A	6.8A	7.0A
3	LP "C" drum level transmitter	Yes	XXX-XXX-XXX	Series constant wattage	14A	10A	7A	4.0A
4	IP "A" drum level transmitter	Yes	XXX-XXX-XXX	Mineral insulated	11A	10.5A	11.2A	10.9A
5	IP "B" drum level transmitter	Yes	XXX-XXX-XXX	Mineral insulated	12A	11A	11.5A	11.2A
6	IP "C" drum level transmitter	Yes	XXX-XXX-XXX	Mineral insulated	5A	7A	6A	6.2A
7	HP "A" drum level transmitter	Yes	XXX-XXX-XXX	Parallel constant wattage	7A	7.5A	7.2A	7.4A
8	HP "B" drum level transmitter	Yes	XXX-XXX-XXX	Parallel constant wattage	12A	10.9A	11.1A	11.3A
9	HP "B" drum level transmitter	Yes	XXX-XXX-XXX	Parallel constant wattage	5A	4.1A	4.5A	5.0A
10	Boiler feed 1A pump flow	Yes	XXX-XXX-XXX	Self regulating	10A	5A	3.5A	1.5A

## Drum level transmitter manifolds and sensing lines freezing are the leading cause of a unit trip or derate – Critical Components

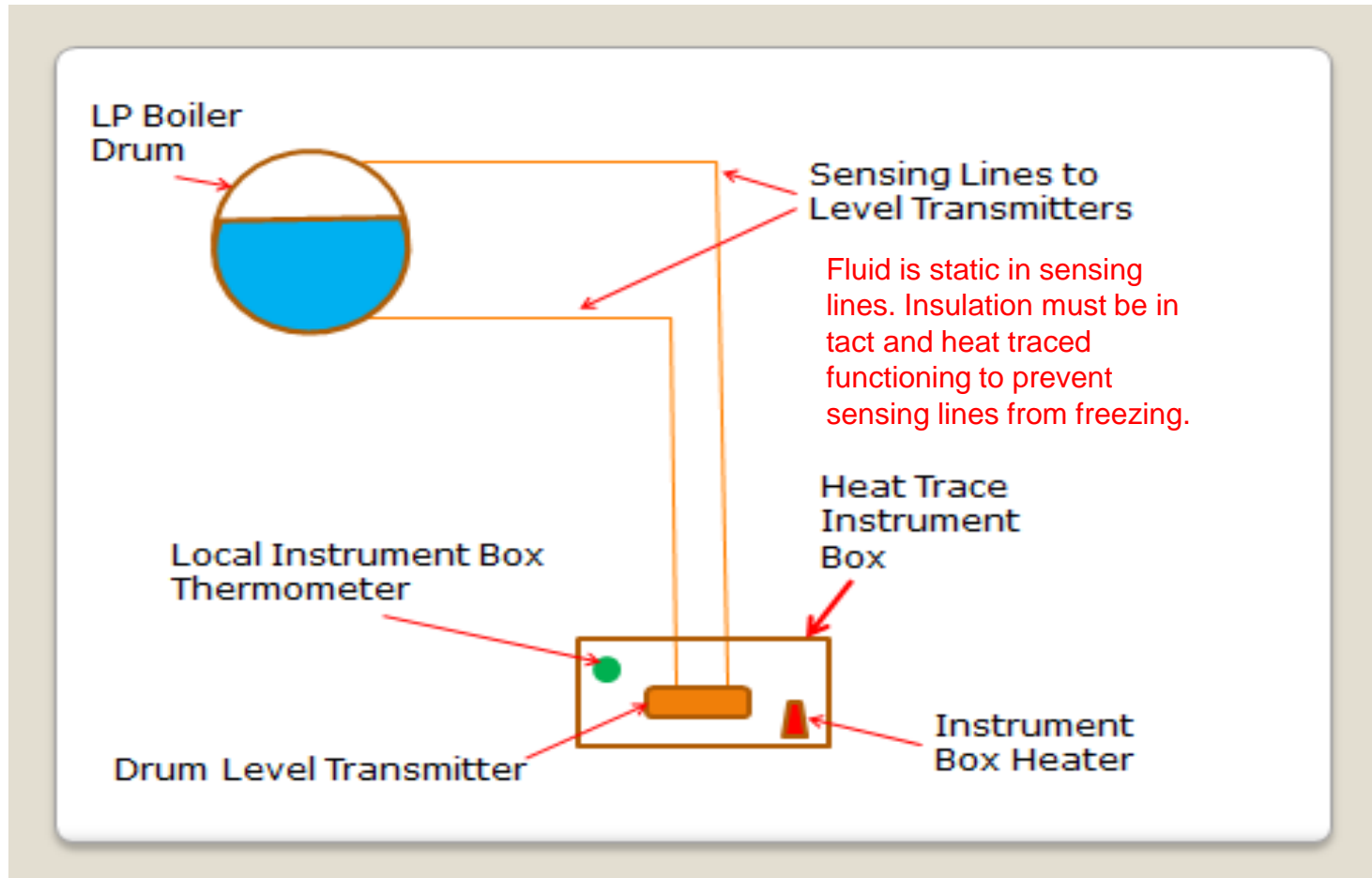

## Insulation inspection results from 2015/2016 spot check

- Sixty-nine units report insulation audits and produced records.
- Ten units could not provide records of insulation inspection.
  - ✓ *Recommended personnel to revise their plan to include insulation inspection.*

## Training results from 2015/2016 spot check

- Seventy units conducted annual training or drills reviewing respective extreme cold weather procedures or other information to refresh personnel.
- Nine units could not provide annual training or drill records.
  - ✓ Recommended personnel to conduct annual training or drill reviewing respective extreme cold weather procedures with records of attendance.
- §25.53. Electric Service Emergency Operations Plans.
  - (C)(2)(4)(d) **Drills.** A market entity shall conduct or participate in one or more drills annually to test its emergency procedures if its emergency procedures have not been implemented in response to an actual event within the last 12 months.

# Heat trace damage caused by insulating contractor



# ERCOT Recommendations

- Develop critical components list to include in their plan with associated heat trace circuit, insulation inspection (and/or wind breaks and/or heaters, if installed).
- Develop spreadsheet record of heat trace audit testing.
  - Record design amperage by circuit (if known), amperage readings, identify critical circuits.
  - Do so for each panel for comparison review.
- Continue or start annual audit on heat trace being mindful of critical components.
- Continue or start annual audit on insulation being mindful of critical components.
- Install thermometers on the outside of critical transmitter cabinets or enclosures.

## ERCOT Recommendations (continued)

- Consider installing end of heat trace circuit lights as a visual indication for operators that circuit is energized.
- Develop a pre-winter checklist for preparation.
- Improve cold weather training or drills focusing on the type of checks required on critical equipment during an event.
- Find another reliable wind break other than a blue off the shelf tarp.
  - Best practice is hardy plank, plywood, heavy duty flame retardant tarp, corrugated sheet metal.
- Capture lessons learned from previous season for inclusion in weatherization plan.
- Improve details of weatherization plan.
- Install wind breaks prior to winter versus installing before an extreme cold weather event.

## Comments

- Identifying critical components is required and measures to mitigate freezing will be a priority during spot checks for 2016/2017.
- Twelve units that were spot checked for 2015/2016 are scheduled again for this December.
- Purpose of this program is to ensure plants are following their plan and assist plants by sharing best practices or lessons learned.
- Plants should be preparing for a one in twenty year event similar to February, 2011.
- ***It is ERCOT's expectation that for every cold weather event, some generation is going to experience freeze related derates or trips.***

# Reference Weatherization Documents

- NERC Cold Weather materials page
  - ✓ <http://www.nerc.com/pa/rrm/ea/Pages/Cold-Weather-Training-Materials.aspx>
- Lessons Learned specific to the southwest cold weather event.
  - ✓ <http://www.nerc.com/pa/rrm/ea/Pages/February-2011-Southwest-Cold-Weather-Event.aspx>

## Food for thought....

- “do or do not; there is no try.” Yoda – Star Wars
- **COMPLACENCY:** a feeling of being satisfied with how things are and not wanting to try to make them better.
- ... you say to yourself, “OK, why did it happen? Why did we make those bad engineering decisions we made in 1967 and 1986 with Challenger?” I'll tell you. It's the human element. I suggest that there's a **complacency** there that comes from success. — Alan Shepard

*ERCOT would like to thank the generator owners, operators and plant staff for their cooperation and efforts on weatherization!*





## **2016-17 Preliminary Winter Weather Outlook**

Chris Coleman  
ERCOT Sr. Meteorologist

Texas RE Winter Weatherization Workshop  
September 7, 2016

# Agenda

- Review of last winter (and other recent winters)
- Current conditions
- Expectations for the upcoming winter

# Temperature Ranking of Recent Winters (Texas)

<b>2015-16</b>	<b>114<sup>th</sup> coldest (out of 121)</b>
2014-15	69 <sup>th</sup>
2013-14	30 <sup>th</sup>
<b>2012-13</b>	<b>108<sup>th</sup></b>
<b>2011-12</b>	<b>99<sup>th</sup></b>
2010-11	69 <sup>th</sup>
<b>2009-10</b>	<b>8<sup>th</sup></b>
<b>2008-09</b>	<b>109<sup>th</sup></b>
<b>2007-08</b>	<b>99<sup>th</sup></b>
2006-07	43 <sup>rd</sup>

# Temperature Ranking of Recent Winters (Texas)

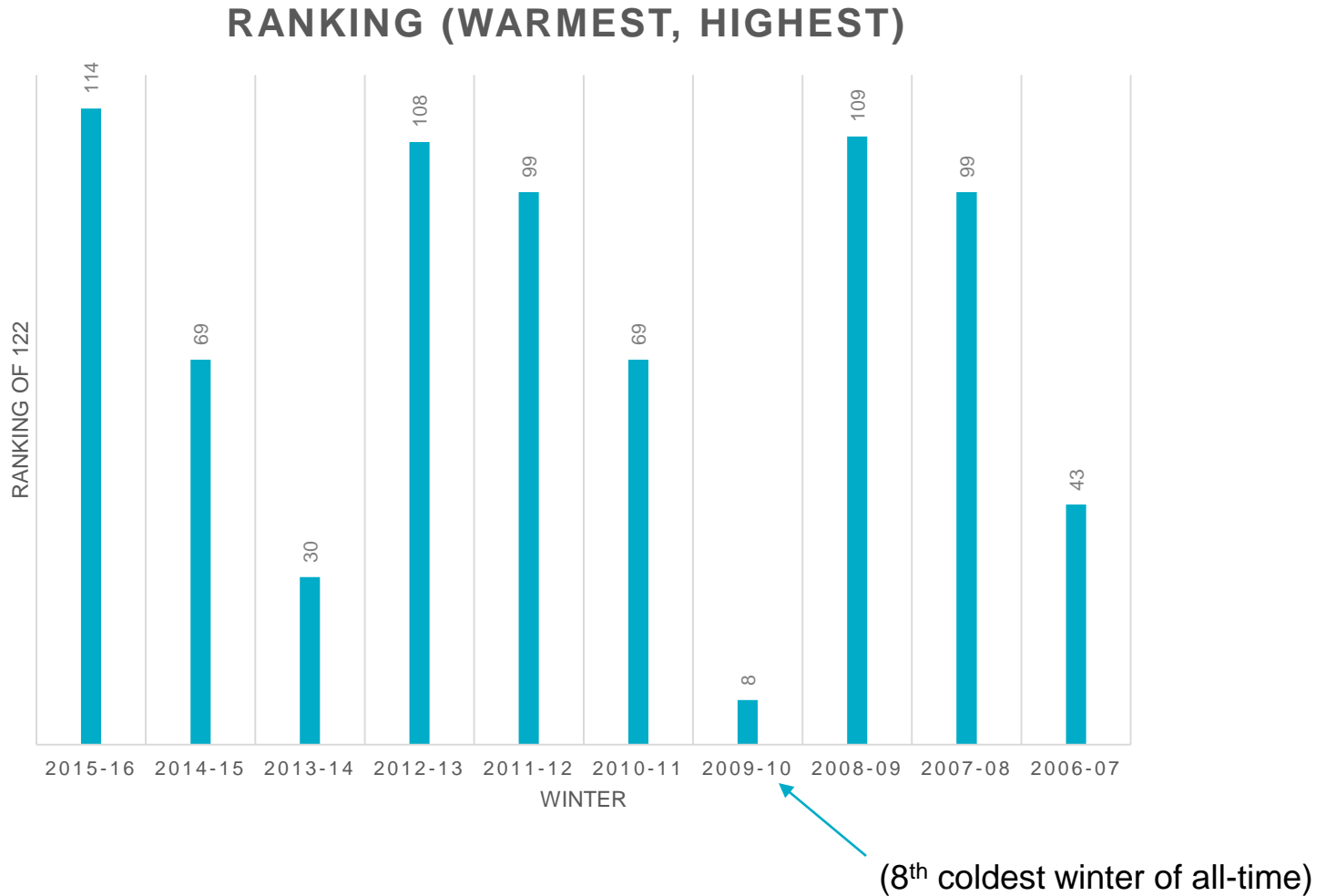

# What Other Weather Companies Were Saying

Winter Outlook 2015/16

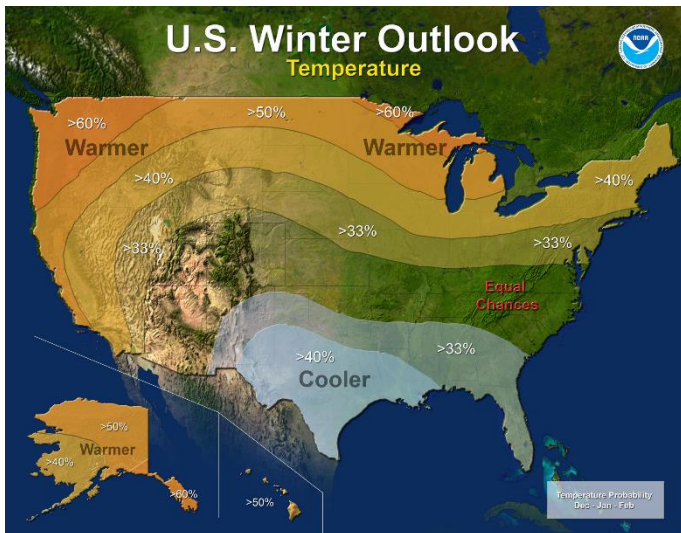
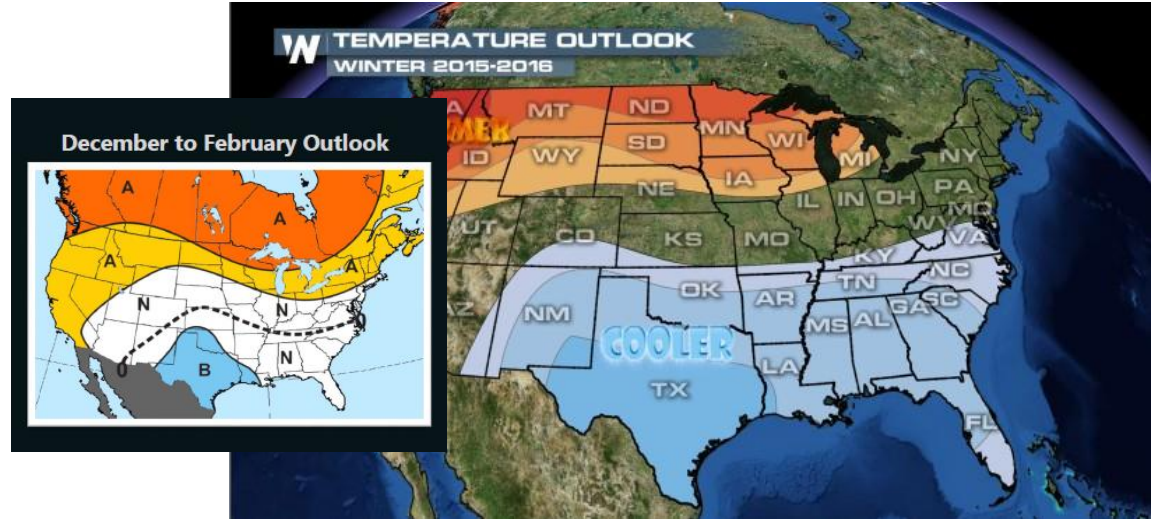
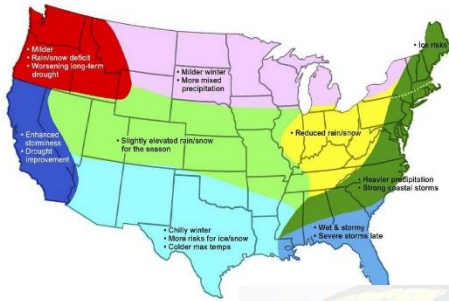

IRI Multi-Model Probability Forecast for Temperature for December-January-February 2016, Issued October 2015

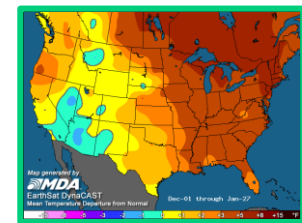
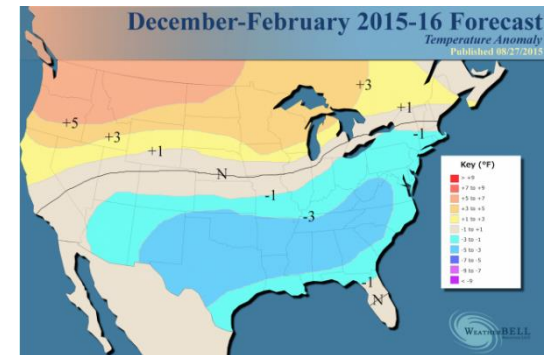
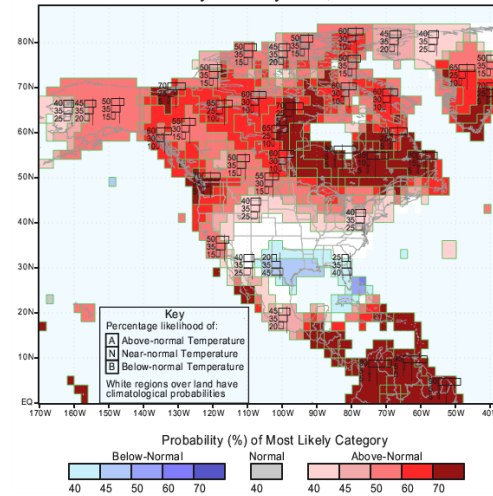

# Reviewing Last Winter's Forecast

## Top Row: Preliminary Forecast given at last September's winterization seminar

Potentially similar to last winter. More warmer potential than cooler – but TBD

Important to emphasize the daytime highs have more below normal potential than the nighttime/morning lows

More similar to last winter (2014-15) than the winter of 2013-14  
Coast and South have greatest below-normal potential.

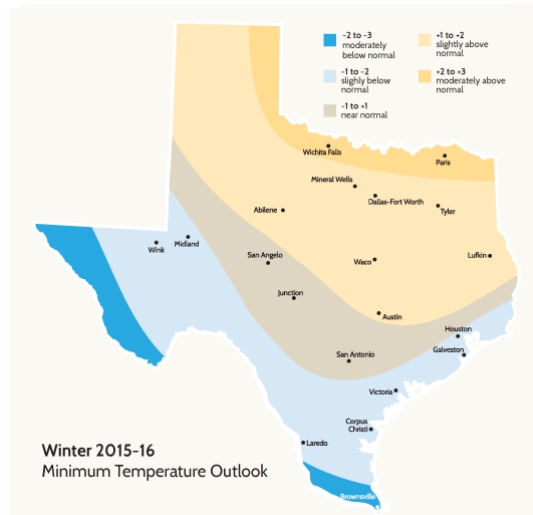
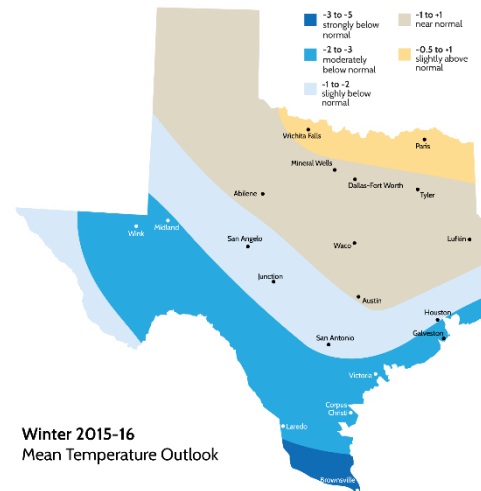
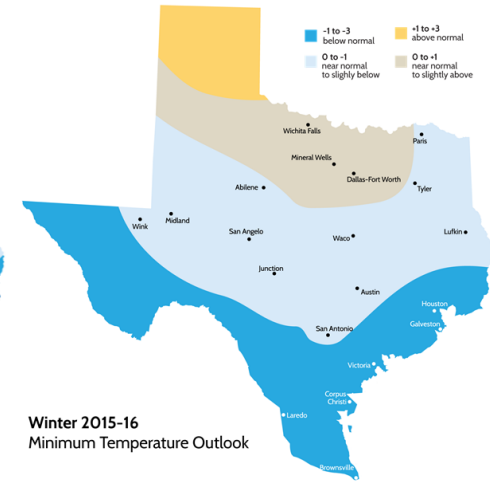
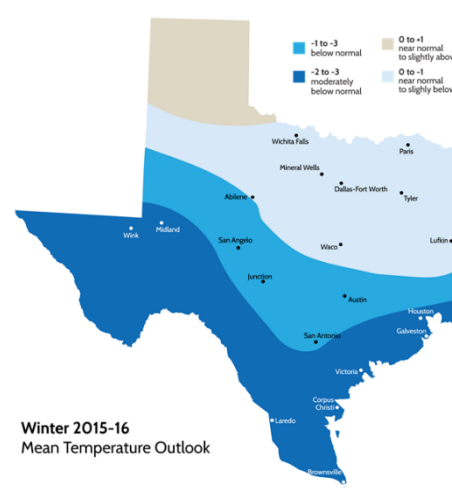

## Bottom Row: Final Forecast, Issued November 1

# Forecast versus Actual

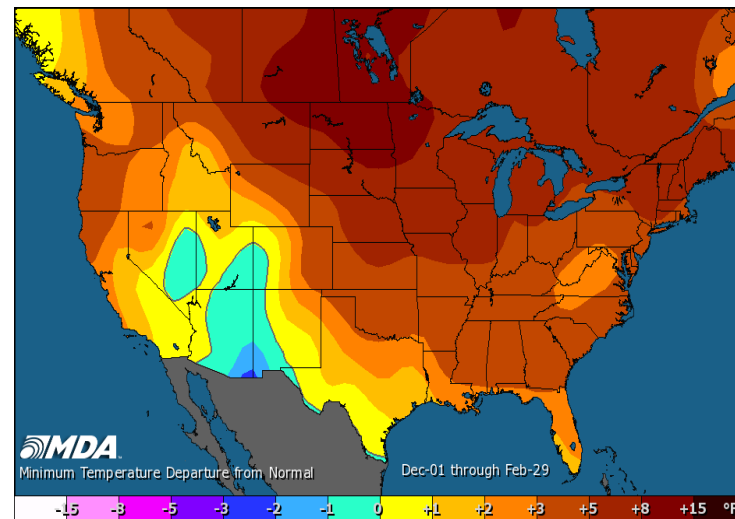
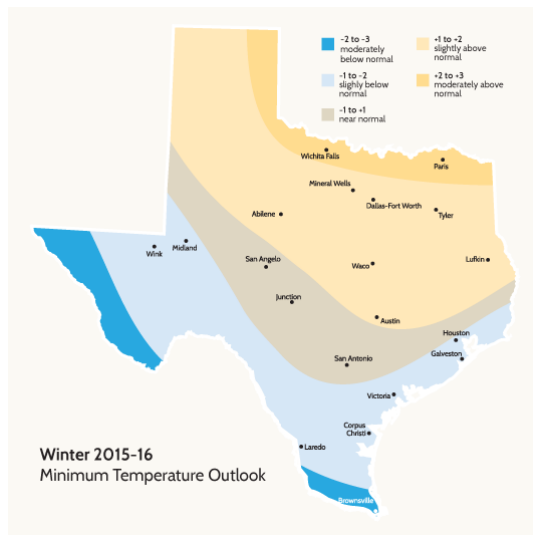
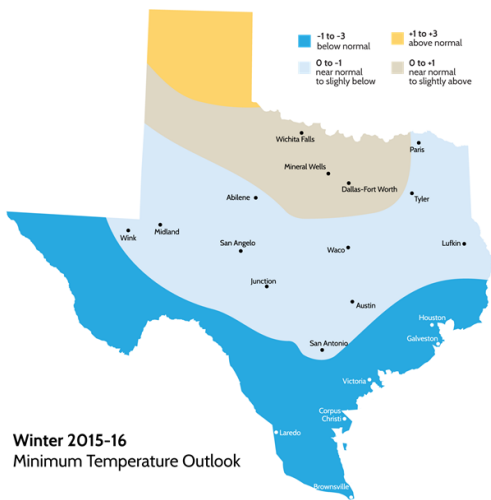

## Preliminary Forecast, Final Forecast, Actual Winter Anomaly (minimum temperatures)

Only 7 winters  
have been  
warmer:  
1990-2000  
1999-99  
1956-57  
1951-52  
1949-50  
1910-11(tie)  
1906-07

# Last Winter's Lack of Austin Freezes

(114<sup>th</sup>)

	2015-16 frz #	COLDEST	#SUB-40
November	1	32	2
December	0	34	8
January	3	31	15
February	1	32	5
	5		30

(69<sup>th</sup>)

	2014-15 frz#	COLDEST	#SUB-40
November	4	30	7
December	2	30	6
January	4	23	20
February	5	30	15
	15		48

(30<sup>th</sup>)

	2013-14 frz #	COLDEST	#SUB-40
November	1	32	10
December	8	27	19
January	9	22	17
February	5	26	12
	23		58

(69<sup>th</sup>)

	2010-11 frz #	COLDEST	#SUB-40
November	0	34	5
December	4	28	13
January	6	26	21
February	9	17	12
	19		51

	1997-98 frz#	COLDEST	#SUB-40
November	0	34	4
December	1	28	17
January	0	36	6
February	1	28	27
	2		54

	avg frz #	avg coldest	avg sub-40 #
November	0.5	34.7	4.2
December	4.3	28.1	13.7
January	4.9	27.3	14.5
February	2.9	28.5	10.9
	12.5	27	43.2

## Notes

- 31° was the coldest minimum temperature recorded last winter.
- In the past 50 winters, that's the warmest minimum temperature.
- Five freezes is the second-fewest total in the past 20 years (1997-98).
- Less than six total hours at or below freezing entire winter in Austin.

# El Niño, La Niña, or Neutral?

Early-Aug CPC/IRI Official Probabilistic ENSO Forecast

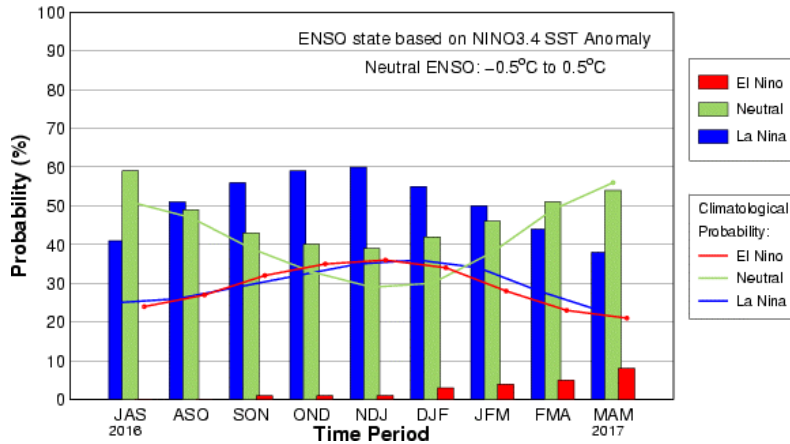

Dec 2016 - Feb 2017 IRI seasonal Forecast SSTA issued 0000 1 Aug 2016

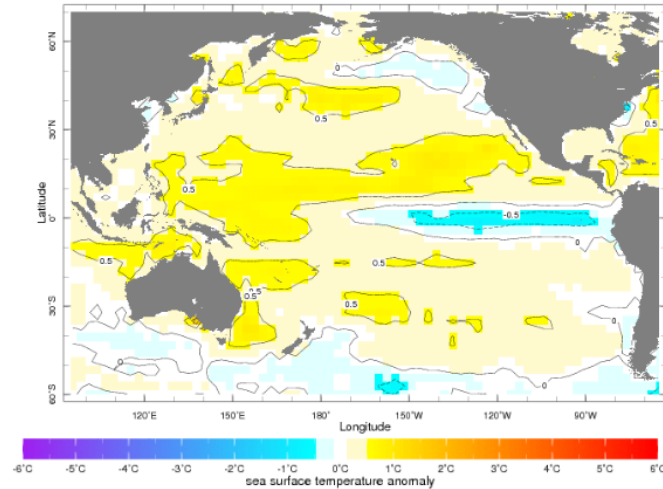

Likely either neutral or weak La Niña this winter.

Weak events suggest other factors could be bigger drivers.

CFSv2 forecast Nino3.4 SST anomalies (K)

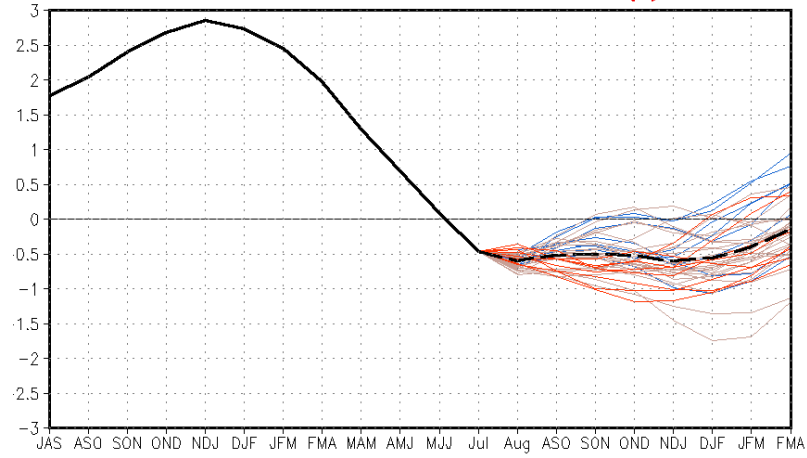

# Pacific Decadal Oscillation

Pacific Ocean is still quite warm. PDO continues strongly positive (warm) and should continue positive through the winter season. The warm Pacific has been a primary driver of weather patterns since 2014.

NOAA/NESDIS 50 KM GLOBAL ANALYSIS: SST Anomaly (degrees C), 8/11/2016  
(white regions indicate sea-ice)

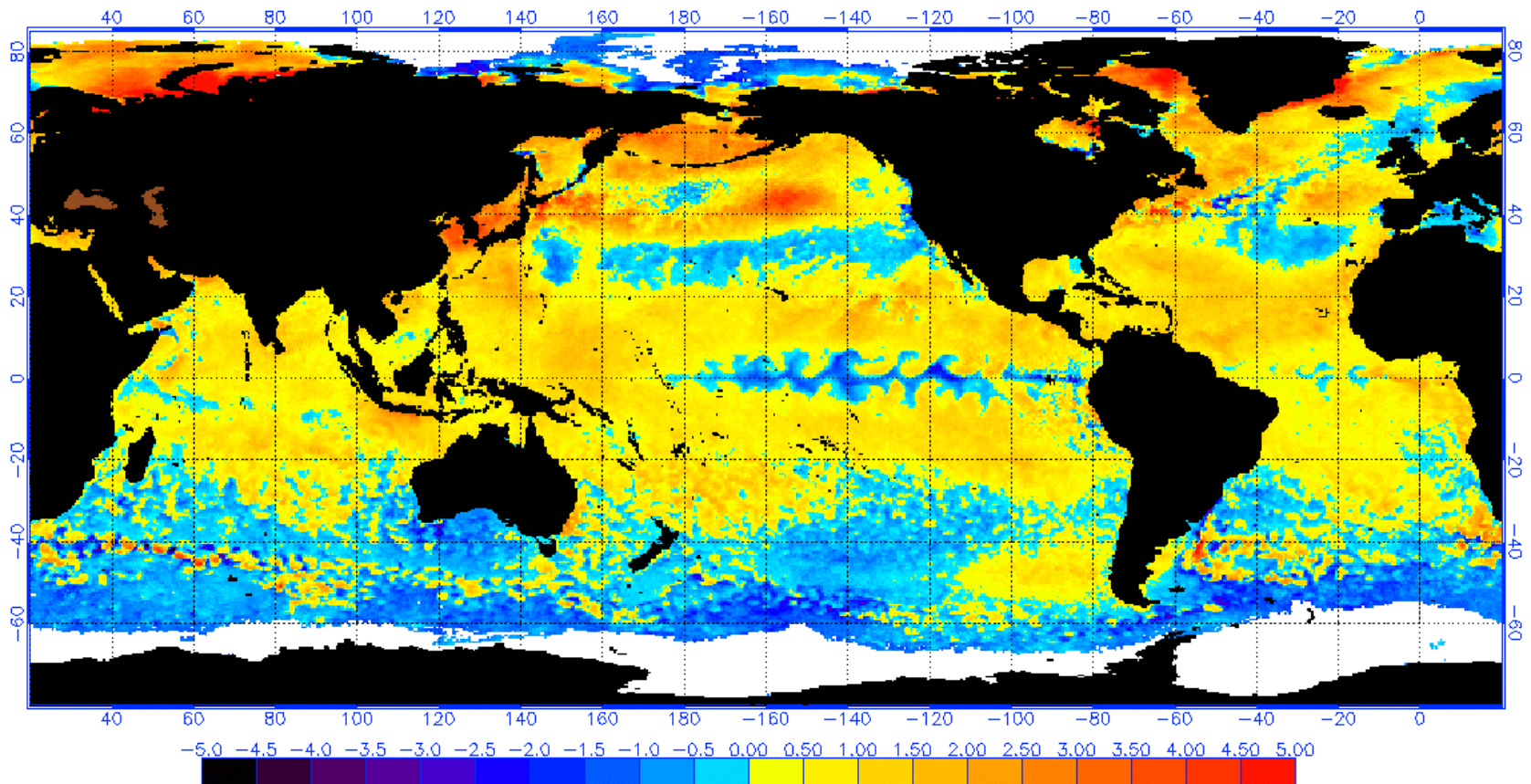

# United States Winter Outlook

Current indicators suggest the trough of low pressure will be mostly located over the Midwest.

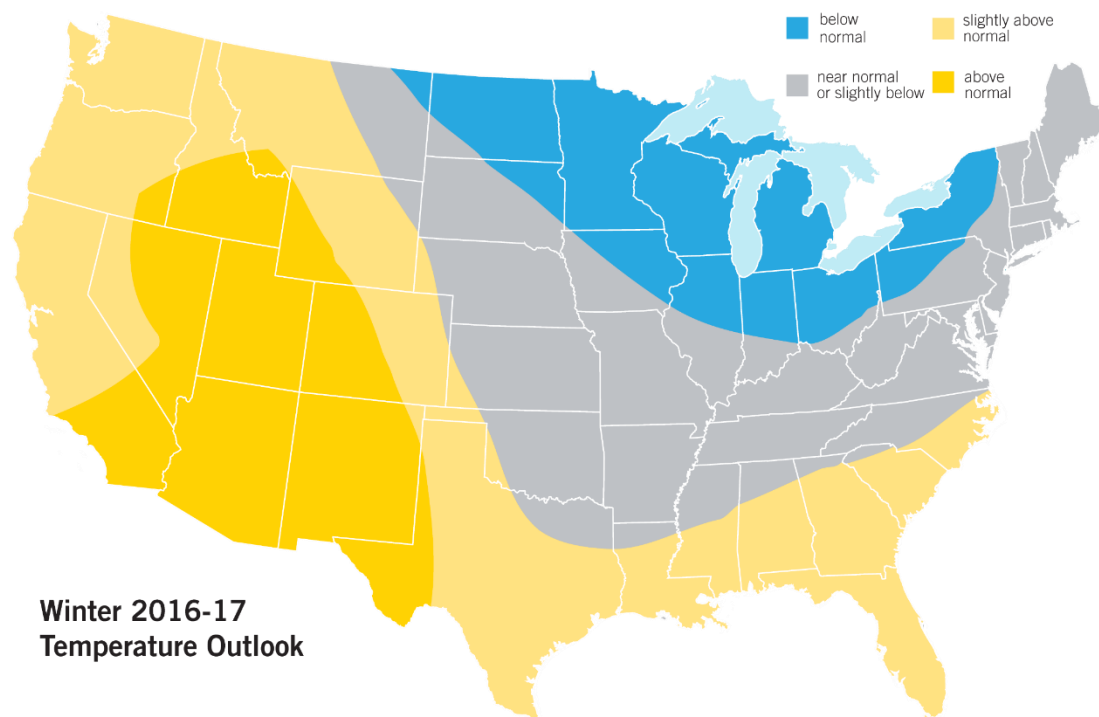

# Winter 2016-17 Temperature Outlook

- **At this time, not seeing a strong cold signal**
- **December has the warmest anomaly potential**
- **January and February could both feature some periods of below-normal temperatures**
- **The overnight/morning lows show a slightly colder (relative to normal) look than the mean temperature**
- **Unlikely to be as warm as last winter (114<sup>th</sup> coldest) ... but not impossible**
- **Very Unlikely to be as cold as the winter of 2013-14 (30<sup>th</sup> coldest)**

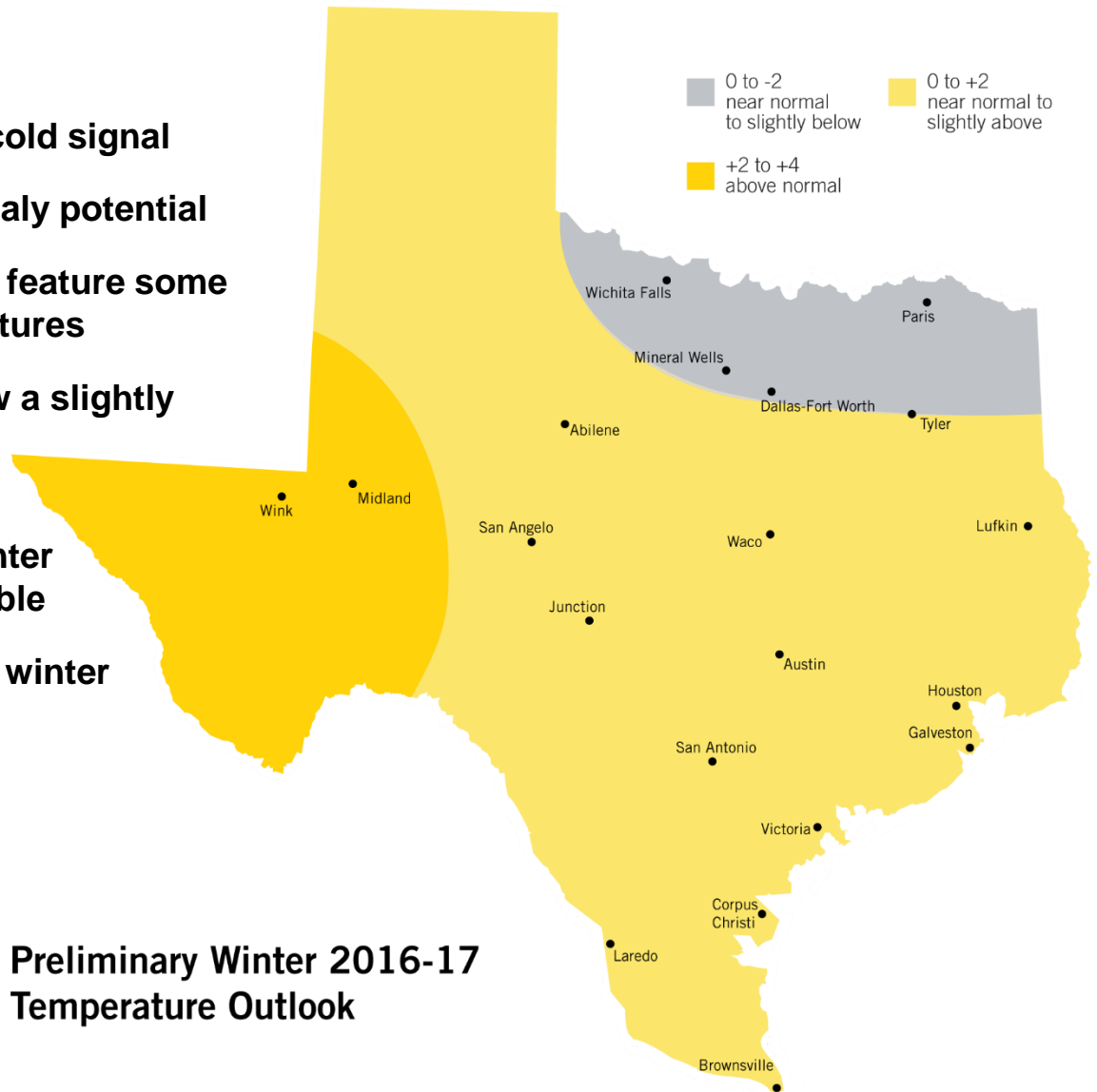

Preliminary Winter 2016-17  
Temperature Outlook

# Secondary scenario

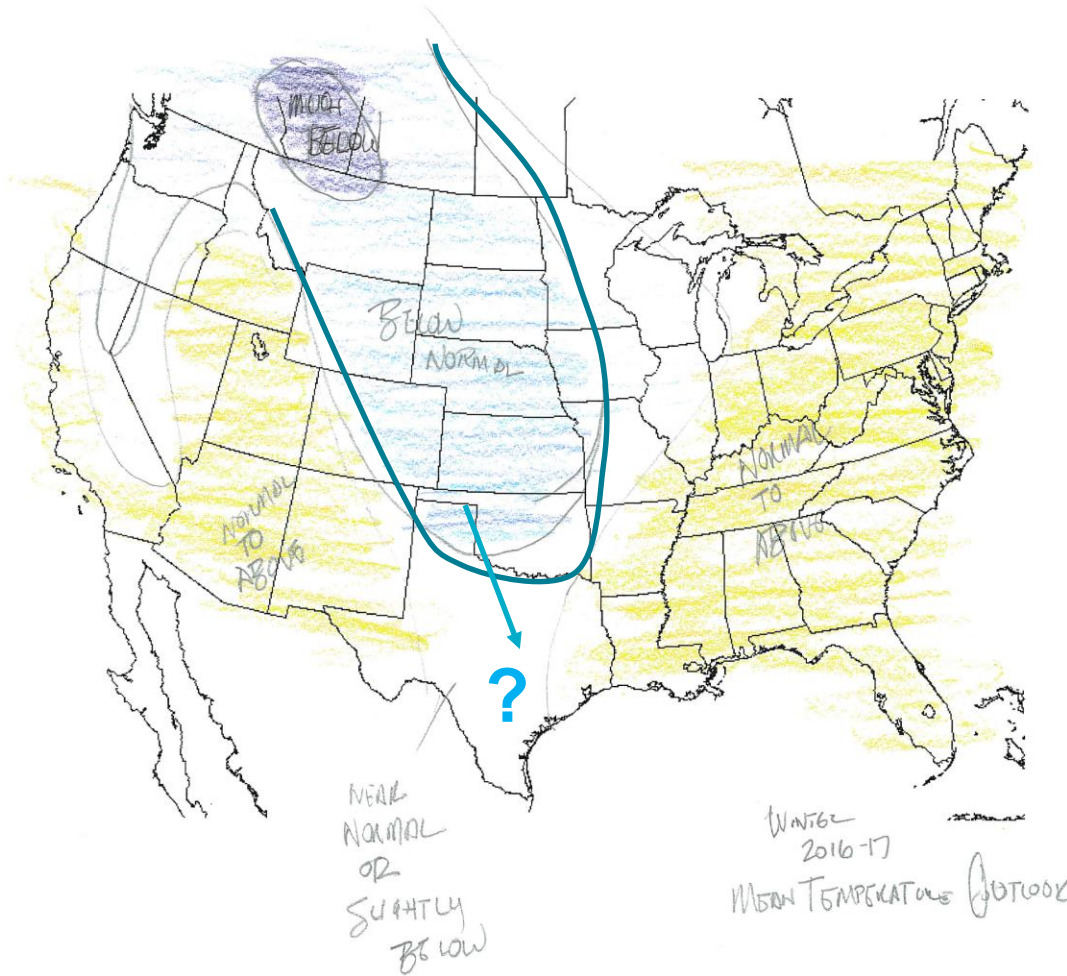

As of today,  
less than 30%  
likelihood

# Precipitation Ranking of Recent Winters (Texas)

2015-16	56 <sup>th</sup> driest (out of 121)
2014-15	70 <sup>th</sup>
<b>2013-14</b>	<b>11<sup>th</sup></b>
2012-13	60 <sup>th</sup>
<b>2011-12</b>	<b>112<sup>th</sup></b>
<b>2010-11</b>	<b>17<sup>th</sup></b>
<b>2009-10</b>	<b>111<sup>th</sup></b>
<b>2008-09</b>	<b>1<sup>st</sup></b>
2007-08	24 <sup>th</sup>
<b>2006-07</b>	<b>104<sup>th</sup></b>

# Winter 2016-17 Precipitation Outlook

- A dry winter forecast has greater likelihood than a warm winter forecast
- Drier than normal especially over West Texas
- Potentially drier than last winter
- Forecasting the 5<sup>th</sup> consecutive winter of either normal or drier-than-normal precipitation

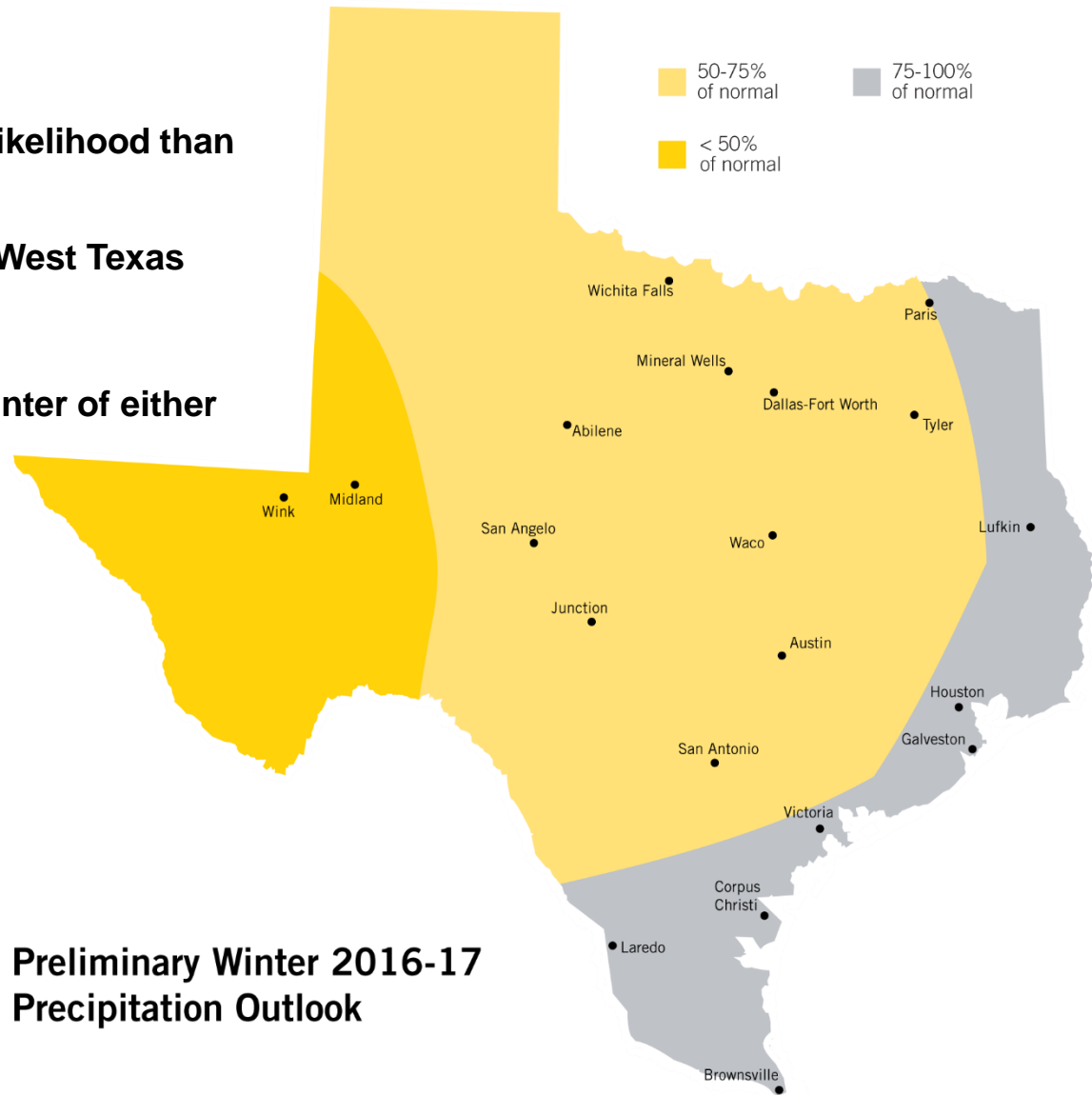

# Historical Analog Winter Snowfalls

- 1993-94, 1981-82, 1998-99, 1958-59, (2005-06, 1995-96, 2015-16).

## Dallas Snowfall

<u>1993-94</u>	<u>1981-82</u>	<u>1998-99</u>	<u>1958-59</u>
0.4"	0.8"	trace	2.5"
<u>2005-06</u>	<u>1995-96</u>	<u>2015-16</u>	
trace	2.4"	trace	
Last Three Winters:			<u>Average</u>
trace, 5.8", 2.9"			2.51"

Winter 2016-17  
Dallas Snowfall  
Forecast:

<1.0 inch = 70%  
probability

>1.0 inch = 30%  
probability

Houston:

Feb '94 = 0.1"

Winter 2016-17  
Houston Snowfall  
Forecast:

Measurable snow  
probability = 15%

Austin:

Jan '82 = 2.0

Feb '96 = 0.3

Winter 2016-17  
Austin Snowfall  
Forecast:

Measurable snow  
probability = 20%

# Historical Analog Winter Snowfalls

- 1993-94, 1981-82, 1998-99, 1958-59, (2005-06, 1995-96, 2015-16).

## Dallas Snowfall

<u>1993-94</u>	<u>1981-82</u>	<u>1998-99</u>	<u>1958-59</u>
0.4"	0.8"	trace	2.5"
<u>2005-06</u>	<u>1995-96</u>	<u>2015-16</u>	
trace	2.4"	trace	
Last Three Winters: trace, 5.8", 2.9"			<u>Average</u> 2.51"

Thanksgiving 1993: Sleet Bowl  
(Dallas vs. Miami)

January 13, 1982: One of the  
heaviest snowfalls in North Texas  
history (though not Dallas)

April 5, 1996: Sweetwater: 18" of  
snow. 9.3 in Abilene (24hr record)

# Ice Forecast (including West Texas)

- **1993-94, 1981-82, 1998-99, 1958-59, (2005-06, 1995-96, 2015-16)**
- Historical ice records are spotty at best
- At this point, the general pattern doesn't support any more ice than last winter (last winter, the most significant events in West Texas were Nov-Dec).
- To note, the winter of 1995-96 (analog for this winter) was the 3<sup>rd</sup> snowiest winter in Abilene history (15.3 inches).
- **I provide two-week out freezing rain/ice forecasts to operations:**

		Freezing Rain Potential							
		12/21-12/27							12/28-1/3
		Monday	Tuesday	Wednesday	Thursday	Friday	Saturday	Sunday	Next Week
<b>West</b>		no risk	no risk	no risk	no risk	no risk	mdt risk	mdt risk	no risk
<b>North</b>		no risk	no risk	no risk	no risk	no risk	mdt risk	mdt risk	no risk
<b>South</b>		no risk	no risk	no risk	no risk	no risk	no risk	no risk	no risk
<b>Panhandle</b>		no risk	no risk	no risk	no risk	no risk	slt risk	no risk	no risk

# Summary

- This is a preliminary forecast. It will be **finalized by November 1** and posted to ERCOT.com
- Early indications suggest a **mild, dry winter**.
- There remains a **scenario that would result in a significantly colder winter** that cannot be dismissed at this point
- **More opportunity for a colder** winter than for a wetter winter
- The overnight/morning lows show a slightly colder (relative to normal) look than the mean temperature
- **Unlikely to be as warm as last winter** (114<sup>th</sup> coldest)
- **Unlikely to be as cold as the winter of 2013-14** (30<sup>th</sup> coldest)
- Better chance to be similar to last winter than the “polar vortex” winter of 2013-14

# Questions?

